



"HENRI COANDA"
AIR FORCE ACADEMY
ROMANIA



GERMANY



"GENERAL M.R. STEFANIK"
ARMED FORCES ACADEMY
SLOVAK REPUBLIC

INTERNATIONAL CONFERENCE of SCIENTIFIC PAPER
AFASES 2011
Brasov, 26-28 May 2011

CONSIDERATIONS REGARDING MODAL TESTING OF ELECTRIC MOTORS PARTS

Melania FILIP*, Ioan Călin ROȘCA**, Elena HELERA***

*Technical Collage, "Mircea Cristea", Brașov, Romania, ** Mechanical Engineering Faculty, Transilvania University, Brașov, Romania, *** Electrical Engineering and Computer Science Faculty, Transilvania University, Brașov, Romania

Abstract: In the present paper there will be presented the main possibilities of modal testing of an electric motor of 1.1 kW power and 1500 rpm. It is developed a practical methodology of impact hammer test procedure of some mechanical components and the associated natural frequencies found by FEM. In the same time there are presented the damping ratio functions found for these parts.

Keywords: modal analysis, electric motor model, experimental test

1. INTRODUCTION

One of the most important problem in mechanical structures analysis it is represented by the response at dynamic loads. From a mathematical point of view, the dynamic response can be modeled by the matrix equation:

$$[\mathbf{M}]\{\ddot{\Delta}\} + [\mathbf{C}]\{\dot{\Delta}\} + [\mathbf{K}]\{\Delta\} = \{\mathbf{F}\}, \quad (1)$$

where $[\mathbf{M}]$ is the inertia matrix, $[\mathbf{C}]$ is the damping matrix, $[\mathbf{K}]$ is the stiffness matrix, $\{\ddot{\Delta}\}$ is the accelerations vector, $\{\dot{\Delta}\}$ is the velocities vector, $\{\Delta\}$ is the displacements vector, and $\{\mathbf{F}\}$ is the dynamic external loads vector.

In equation (1) both matrixes $[\mathbf{M}]$ and $[\mathbf{K}]$ can be expressed in a direct way while the damping matrix $[\mathbf{C}]$ can be defined as a linear combination of inertia and stiffness matrixes:

$$[\mathbf{C}] = \alpha[\mathbf{M}] + \beta[\mathbf{K}], \quad (2)$$

where α and β are two coefficients.

The values of α and β coefficients can be found as functions of frequency. When the mode shapes have proportional damping, between these two coefficients can be written the relationship:

$$\alpha + \beta\omega_i^2 = 2\omega_i\zeta_i, \quad (3)$$

where ω_i is the rotary frequency, given in rad/s, that corresponds to the mode shape "i" and ζ_i is the damping ratio of the same mode shape [4].

A good approach of the finite element model of any mechanical structure involve a good approximation of the damping, especially internal damping. This means to find the damping ratio as function of frequency. The

damping ratio values can be found only by modal experimental tests.

2. THE FINITE ELEMENT MODELS

There were analysed three parts of the electrical motor: the rotor, the stator and the electric motor frame. All these three parts were modelled 3D in IDEAS and the finite element analysis was done using the ABAQUS soft.

2.1 The rotor. The 3D model was done considering the detailed draw considering the main dimensions and particularities of the part. The finite element model consists of 7015 nodes and 32495 elements (Figure 1).

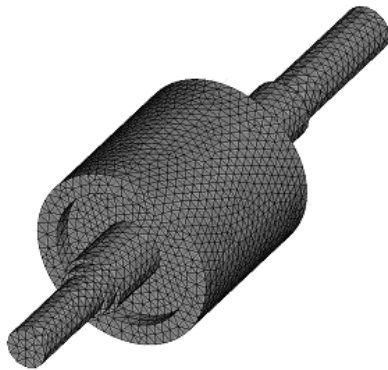

Figure 1

The considered material density was chose according with the real mass of 2.9 kg and the Young's modulus took into the consideration was the value of steel $E = 2.1e5$ MPa.

There were analysed three different cases of boundary conditions: free-free, simply supported on the bearings mounting region and fixed with special elements spring that have the same stiffness as the bearings.

Considering the case of free-free rotor there were found the first six zero natural frequencies and the following ten important natural frequencies: 43.099 Hz, 56.521 Hz, 128.44 Hz, 138.16 Hz, 271.86 Hz, 389.95 Hz, 519.81 Hz, 587.22 Hz, 619.34 Hz and 699.77 Hz. Practically, one is interested in all mode shapes and considering the visualised imagines of the deformed shape for the first ten natural frequencies all are of bending mode excepting the value of 271.86 Hz that corresponds for the torque mode.

2.2 The stator. As in the previous case, the stator 3D model was done based on detailed

draw. The finite element model consists of 9971 nodes and 38029 elements (Figure 2).

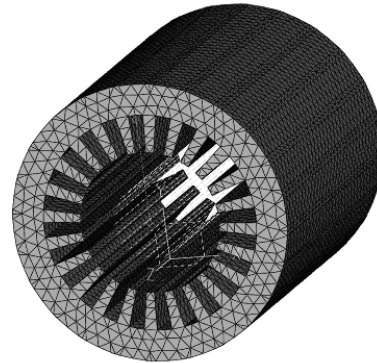

Figure 2

For an approached modal analysis the stator was weighed, without coiling. The total mass was about 2.5 kg and it was considered a material density that gives this weight for the model. The Young's modulus took into the consideration was the value for steel $E = 2.1e5$ MPa.

The stator was considered free. The first six natural frequencies were zero and then there were found the following important natural frequencies: 70.132 Hz, 133.84 Hz, 184.43 Hz, 300.57 Hz, 323.32 Hz, 340.26 Hz, 376.63 Hz, and 407.14 Hz. All these values correspond to the bending mode shapes.

2.3 The electric motor frame. The 3D model was done considering the detailed draw. This part of the electrical motor is done of aluminium castings with a real mass of 1.3 kg.

The finite element model consists of a number of 66.725 elements and 21.644 nodes (Figure 3).

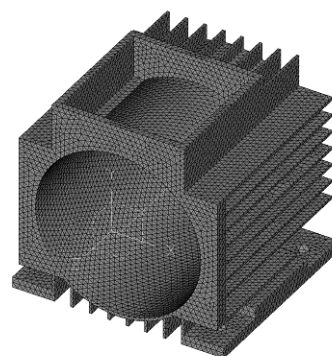

Figure 3

The density value was choose to obtain for the FE model the same mass and the Young's



"HENRI COANDA"
AIR FORCE ACADEMY
ROMANIA



GERMANY



"GENERAL M.R. STEFANIK"
ARMED FORCES ACADEMY
SLOVAK REPUBLIC

INTERNATIONAL CONFERENCE of SCIENTIFIC PAPER
AFASES 2011
Brasov, 26-28 May 2011

modulus was $E = 0.7e5$ MPa, the value for aluminium.

This part, as the other two, was considered as free-free boundary conditions. Besides the six values of zero for natural frequencies were also found the following main values: 18.577 Hz, 28.952 Hz, 37.043 Hz, 47.640 Hz, 59.094 Hz, 76.488 Hz, 97.427 Hz, 119.90 Hz, 136.79 Hz, and 148.64 Hz.

3. EXPERIMENTAL SET-UP

Experimental modal analysis was done using the method of impact hammer. The used equipment was: impact hammer type 8206-003 Brüel&Kjær, four accelerometers type 4507B Brüel&Kjær, Pulse 12 platform type 3050 Brüel&Kjær, programs for signal processing type 7705 and 7709, and soft ME'scopeVES, v.5. The applied procedure of modal testing was that that is described in technical literature [1, 2, 3, 5, 6].

3.1 The rotor modal analysis. The set up is presented in figure 4.



Figure 4

All the four accelerometers were mounted around the rotor at 90° (Figure 5). The hammer hits were applied between the accelerometers and the used tip was aluminium made.

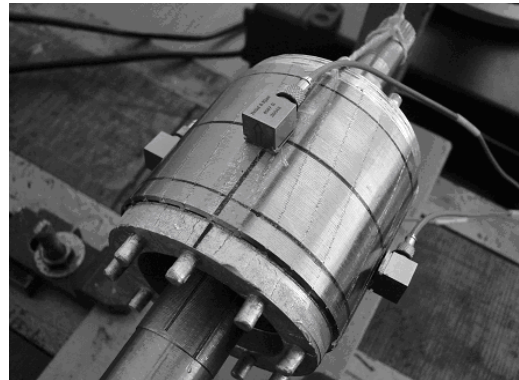

Figure 5

The signals were recorded both in time and frequency domains. The time domain response shapes, in all testing cases, were like the graph presented in Figure 6, and the frequency response shape is presented in Figure 7.

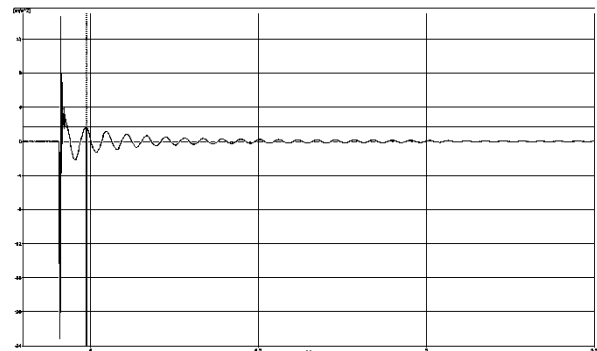

Figure 6

Considering the measurements done at all four accelerometers it was found an average global damping ratio of $\zeta = 0,08475$, and an average damping period of $T_a = 0,067$ s.

Based on these values one can find the damping frequency $\omega_a = 93,778$ [rad/s].

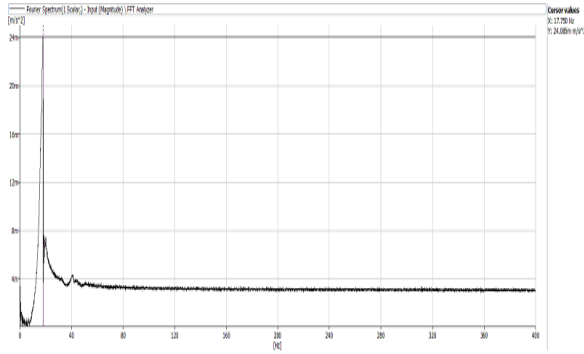

Figure 7

Thus the natural frequency is:

$$\omega_n = \frac{\omega_a}{\sqrt{1-\zeta^2}} = 94,116[\text{rad/s}], \quad (4)$$

and $f_n = 14,979 \text{ Hz}$.

In the same time, the recorded signals were analysed using the ME'scopeVES, v.5 soft (Figure 8).

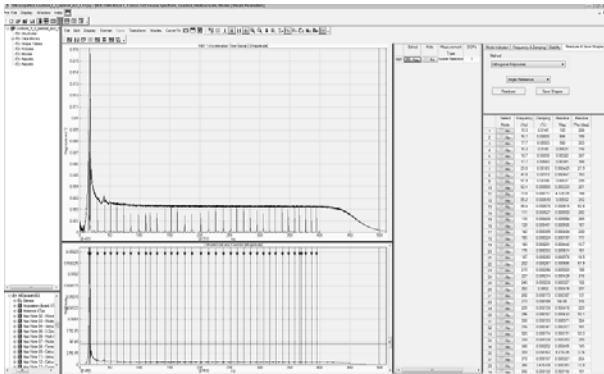

Figure 8

Based on this soft it was possible to be found, for different frequencies, the damping ratio ζ . Taking into consideration the founded values it was calculated, in MatLab a function of damping ratio as (Figure 9):

$$\zeta(f) = e^{-0,971422 f^{-2,574125}} \quad (5)$$

with a regression coefficient of $R^2 = 0,881$ and f is the frequency in Hz.

The first five natural frequencies found were: 15.3 Hz, 29.8 Hz, 42.9 Hz, 62.4Hz, and 85.2 Hz.

3.2 The stator modal analysis. The results obtained in case of rotor were very pour with a

lot of distortions. As cause it was considered the structure with many armature laminations that were not perfect mounted. The whole could not work as a single structure and there were recorded many frequencies generated by the uncoupled armature that vibrate alone (as single bodies).

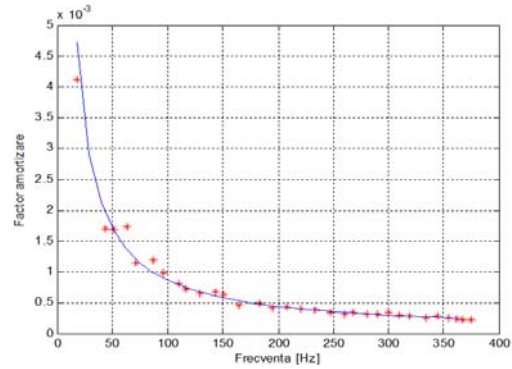

Figure 9

3.3 The electric motor frame modal analysis. As in the case of the stator, the frame was simply supported on a thick sponge part (Figure 10). There were considered three point for signal measuring, denoted by 1,2 and 3 in Figure 10.

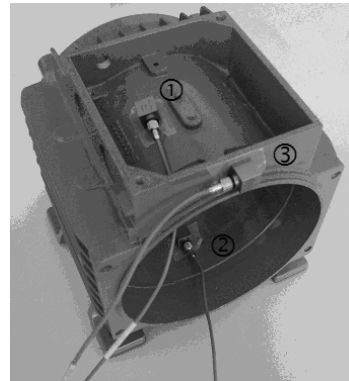

Figure 10

The test consists of set of five hits in four different points, around the frame. The time response (Figure 11) and the frequency response (Figure 12) recorded at all three accelerometers had the same shape.

The signals measured by all accelerometers were analysed using the ME'scopeVES, v.5 soft (Figure 13).



"HENRI COANDA"
AIR FORCE ACADEMY
ROMANIA



GERMANY



"GENERAL M.R. STEFANIK"
ARMED FORCES ACADEMY
SLOVAK REPUBLIC

INTERNATIONAL CONFERENCE of SCIENTIFIC PAPER
AFASES 2011
Brasov, 26-28 May 2011

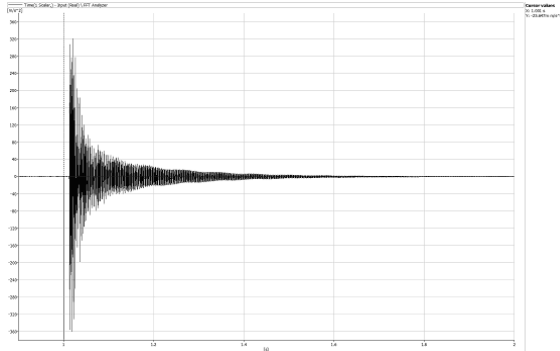

Figure 11

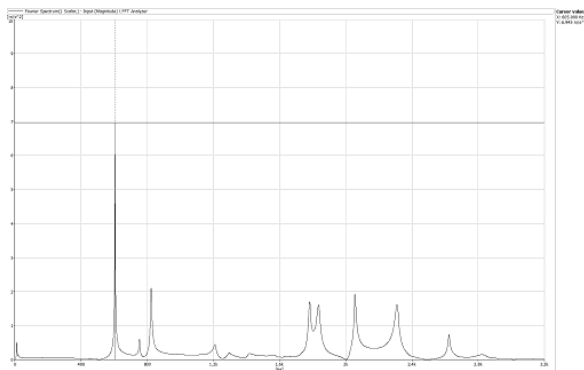

Figure 12

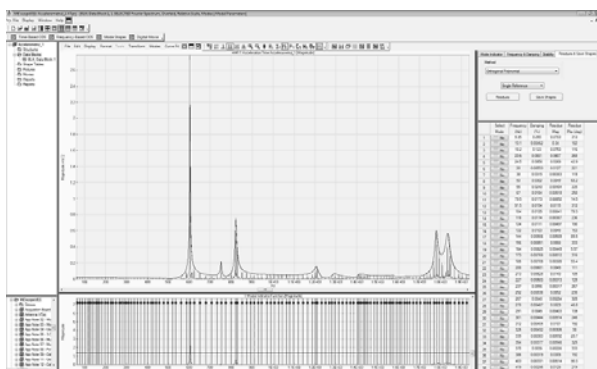

Figure 13

The damping ratio ζ for different frequencies was found based on the data processed with this soft. In MatLab was defined a function of damping ratio as (Figure 14):

$$\zeta(f) = e^{1,2293} f^{-0,9853} \quad (6)$$

with a regression coefficient $R^2 = 0,898$ and f is the frequency, in Hz.

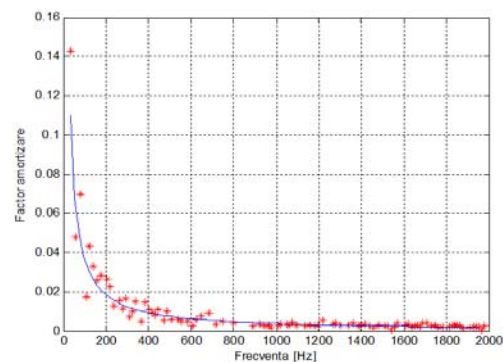

Figure 14

The measured natural frequencies were: 14.0 Hz, 604.5 Hz, 753,5 Hz, 823.0 Hz and 1304 Hz. As it can be seen in relationships (5) and (6) the obtained damping ratio ζ has an exponential variation law as function of frequency. Both functions offer an approximate calculation in the range up to 400 Hz.

4. CONCLUSIONS

In the frame of this paper there were presented two possibilities of finding the natural frequency of three mechanical parts of electric motors: one based on finite element method and the other one based on experimental set-up.

The importance of parts natural frequencies results from the need resonance phenomenon avoid. In the same time any fault can be associate with working frequencies that is close to natural frequencies.

The finite element models are pure mathematical models and the values that were

found can be influenced by the assumptions done in parts modelling.

In case of rotor, in the first five determined natural frequencies there were found only two values that are approximately equals: 43.099 Hz and 56.521 Hz – FEM, and 42.9 Hz and 51.9 Hz - modal testing. In the case of the stator it was difficult to be found the experimental natural frequencies as was above described. In the case of the electric motor frame it was found only one approached value in case of low frequencies but for the high frequencies there very close values. This can be explained by the fact that the high values are associated with the cooling flange vibrations.

Based on experimental modal analyses there were found two functions of damping ratio variation, relationships (5) and (6). These functions can be used in any finite element soft to create the model of structural damping described by the relationship (2).

REFERENCES

1. Dimarogonas, A. – *Vibration for Engineers*, Prentice Hall, second edition, ISBN 0-13-456229-1, 1996
2. Ewins, D., J. – *Modal testing: practice and theory*, John Wiley & Sons Inc., New-York, ISBN 0-471-90472-4, 1986
3. Gafișanu, M.; Creșu, Sp.; Drăgan, B. – *Diagnosticarea vibroacustică a mașinilor și utilajelor*, Editura tehnică, 1989, ISBN 973-31-0123-0.
4. Pascariu, I. – *Elemente finite. Concepte-aplicații*, Editura Militară, București, 1985
5. Zubrenkov, B., I.; Senkina, V., V. - Modal Analysis of the Structure of Rotary Machines with Roller Bearings, *Russian Engineering Research*, 2010, Vol. 30, No. 5, pp. 442–445, ISSN 1068_798X, Allerton Press, Inc., 2010
6. *** - The Fundamentals of Modal Testing, Application Note 243 – 3, Agilent Technologies. *Source* [online]. Available: www.agilent.com/find/assist