

**"HENRI COANDĂ"  
AIR FORCE ACADEMY**



**ROMANIA**

**"GENERAL M.R. STEFANIK"  
ARMED FORCES ACADEMY**



**SLOVAK REPUBLIC**

**STUDENTS' INTERNATIONAL CONFERENCE**

**AFASTUD**

**17<sup>th</sup> Edition**

*Communicating Across Cultures*



**MILITARY STUDENTS'  
ASSOCIATION BRASOV**



**"HENRI COANDĂ"  
ASSOCIATION FOR RESEARCH  
AND EDUCATION**



***20<sup>th</sup> "Henri Coandă" Air Force Academy Anniversary  
1995-2015***

**ISSN, ISSN-L: 2360-0152**

**April 2-4, 2015  
BRASOV - ROMANIA**

## SCIENTIFIC ADVISORS

Col. Prof **Mircea BOȘCOIANU**, PhD  
*“Henri Coandă” Air Force Academy,  
Brașov, Romania*

Dipl.Eng. **Lukáš BRIDÍK**, PhD  
*Armed Forces Academy of General Milan  
Rastislav Stefanik, Slovak Republic*

Assoc Prof **Doru LUCULESCU**, PhD  
*“Henri Coandă” Air Force Academy, Brașov,  
Romania*

Assoc Prof **Daniela BELU**, PhD  
*“Henri Coandă” Air Force Academy, Brașov,  
Romania*

Assoc Prof **Diana ILIȘOI**, PhD  
*“Henri Coandă” Air Force Academy, Brașov,  
Romania*

Assoc Prof **Adrian LESENCIUC**, PhD  
*“Henri Coandă” Air Force Academy, Brașov,  
Romania*

Lect **Constantin STRÎMBU**, PhD  
*“Henri Coandă” Air Force Academy, Brașov,  
Romania*

Lect **Mihaela SMEADĂ**, PhD  
*“Henri Coandă” Air Force Academy, Brașov,  
Romania*

LTC Lect **Laurian GHERMAN**, PhD  
*“Henri Coandă” Air Force Academy, Brașov,  
Romania*

LTC Lect **Ionică CÎRCIU**, PhD  
*“Henri Coandă” Air Force Academy, Brașov,  
Romania*

## EDITORIAL BOARD

### EDITOR-IN CHIEF

Maj lect **Cosmina ROMAN**, PhD  
*“Henri Coandă” Air Force Academy, Brașov,  
Romania*

### EDITORIAL ASSISTANT

Maj **Cristea-Gabriel RĂU**  
*“Henri Coandă” Air Force Academy, Brașov,  
Romania*

### EDITOR

Capt. TA **Cosmin IVANCIU**  
*“Henri Coandă” Air Force Academy, Brașov,  
Romania*

### DESIGNER

Eng. **Mariana GHINDĂOANU**  
*“Henri Coandă” Air Force Academy, Brașov,  
Romania*

The editorial board claims no responsibility concerning the scientific contents of the published papers in this issue. The authors take the full responsibility for the contents. No part of this publication may be reproduced, partially or totally, without the prior written permission of the publishing board.

“Henri Coandă” Air Force Academy Publishing House

ISSN, ISSN-L: 2360-0152



"HENRI COANDA" AIR FORCE ACADEMY  
FACULTY OF AERONAUTICAL MANAGEMENT  
ROMANIA

STUDENTS' INTERNATIONAL CONFERENCE AFASTUD 2015  
*Communicating Across Cultures*  
Brasov, 2<sup>nd</sup>-4<sup>th</sup> April 2015



"GENERAL M.R. STEFANIK"  
ARMED FORCES ACADEMY LIPTOVSKY MIKULAS  
SLOVAK REPUBLIC

## CONTENTS

1.	<b><i>EXPERENTIAL LEARNING-THE FIRST STEP TOWARD A MODERN EDUCATION</i></b> <b>Teodora DOBRE</b>	5
2.	<b><i>HYBRID GEAR UNMANNED GROUND VEHICLE BPPV-01</i></b> <b>Filip FRANÓ</b>	11
3.	<b><i>MEASUREMENT OF RADAR CROSSECTION BY USING DOPPLER METHOD</i></b> <b>Zsolt KISS, Kristóf FÁBIÁN</b>	17
4.	<b><i>ANALYSIS OF NETWORK COMMUNICATION USING FPGA</i></b> <b>Michal KOVÁČ, Michal TURČANIK</b>	23
5.	<b><i>IS THE RUSSIAN FEDERATION A SMART BEAR?</i></b> <b>Tiberiu LAZĂR, Codruț GHINEA</b>	29
6.	<b><i>SIMULATION OF SIMPLEX RADIO COMMUNICATION NETWORKS</i></b> <b>Marek LIPTÁK</b>	37
7.	<b><i>THE EFFECTS OF ASHKENAZI ETHNIC SEGREGATION ON THE DEVELOPMENT OF YIDDISH. SPEIFIC PATTERNS IN VOCABULARY</i></b> <b>Ilie Iulian MITRAN, Mihaela RUS, Mihaela SANDU</b>	43
8.	<b><i>COMPARATIVE STUDY BETWEEN 'GEPARD B2L' ANTI-AIRCRAFT DEFENCE SYSTEM AND 'GDF- 103 AA-OERLIKON' ANTI-AIRCRAFT CANNON</i></b> <b>Cosmin-Viorel RUSU</b>	51

9.	<b><i>COMPARATIVE ANALYSIS ON THE IMPLEMENTATION OF THE APPROACH FLIGHT WITH ILS AND MLS SYSTEMS USE</i></b> Cătălin Ionuț STROESCU	57
10.	<b><i>HOW DOES TERRORISM INFLUENCE THE AIRPORT SECURITY SYSTEMS?</i></b> Vivien SZABÓ, Péter SZEGEDI	63



"HENRI COANDA" AIR FORCE ACADEMY  
FACULTY OF AERONAUTICAL MANAGEMENT  
OMANIA

STUDENTS' INTERNATIONAL CONFERENCE AFASTUD 2015  
*Communicating Across Cultures*  
Brasov, 2<sup>nd</sup>-4<sup>th</sup> April 2015



"GENERAL M.R. STEFANIK"  
ARMED FORCES ACADEMY LIPTOVSKY MIKULAS  
SLOVAK REPUBLIC

## EXPERIENTIAL LEARNING – THE FIRST STEP TOWARDS A MODERN EDUCATION

**Teodora DOBRE**

National Intelligence Academy "Mihai Viteazul", Bucharest, Romania

**Abstract:** *The recent developments in technology and software have propelled society towards progress in almost every aspect of social life, changing the parameters within which people accessed information. Impacting directly the educational progress, Internet offered the possibility of an authentic learning experience through virtual reality, simulation and modelling. Generically known as serious gaming, it comes as a complementary stage of education, replenishing the educational cycle initiated by lecturers, who offer a theoretical basis for concepts, processes and techniques. Removing the trainee from the educational landscape defined by the culture of the right answer, placing him in a new environment and determining him to make decisions based on previous theoretical knowledge will enable learning, which is the main goal of education. My paper addresses the issue of experiential learning as a necessary element in the process of educating and training within a military organization, focusing on the objectives of education and training and how they are met through serious gaming.*

**Keywords:** *education, experiential learning, serious gaming, simulation, military organization*

### 1. INTRODUCTION

In matters of accessing information, the last decades have generated instruments that changed the parameters within which the individual acquires and acknowledges data and information. Shifting from public libraries and personal encyclopedias to personal computer and the World Wide Web, for every generation accessing information was a process different than either one had experienced before. In time, the interaction between the individual and the informational space has changed and the distance between them was considerably lowered.

But while the developments in technology and software allowed almost instant access to worldwide information; it also grew individuals apart from knowledge. Initially,

Internet was perceived as a force of good, of democratization, capable of breaking barriers in places where conventional offline information couldn't (Nita, 2011, 138). However, statistics reveal that in countries with a strong democratic culture, Internet is used mostly for entertainment, and in countries ruled by authoritarian leaders, the access to Internet and information is strictly limited and controlled.

So how can we use the positive force of Internet in matters of education, in the broadest sense? In the attempt to answer this question, my paper focuses on military organization, specifically the intelligence organization and addresses the issue of exploiting the educational power of Internet and technology through serious gaming.

## 2. SIMULATIONS, MODELLING AND EXPERIENTIAL LEARNING

**2.1 Conceptual framework.** Modeling is the process of creating, experimenting, and practicing with a computerized model of a physical system that receives input and provides output for some purpose (Chung, 2004, 16). Models are replica of the real world, defined in parameters of space and time, limited by the trainer in educational purposes. A simulation is the “operation of a model of the system” (Maria, 1997, 7). Through simulation, the model is modified, offering the possibility of repeated observation of the same event, in order to identify the mechanisms, procedures of the exercises inferred.

In other words, modeling consists in “copying” the external environment and its inherent interactions, considered to be referential for the area of study, while simulation provides a practical exercise within the given environment, the trainee having multiple courses of action at his disposal. The role of simulation in this process is to generate answers and follow the decision-making reasoning of the trainee: on which indicators did he substantiate his decision, what events acted as triggers in the decision-making process, the degree of control exerted by the trainee in unexpected crisis situations.

When designing and implementing a simulation exercise, one must take into account the existent entities of the studied system, the relationships and interactions between them, the variables used as input and the indicators of performance, which will further represent the basis for evaluation. According to Maria (Maria, 1997, 8), the development of an efficient simulation must follow 11 steps, starting with identifying the problem, or the learning objective of the exercise. This is probably the most important step when developing a simulation exercise, due to the fact that the following measures taken must aspire to meeting that objective. After formulating the problem, the designer should start collecting and processing real system data, based on which he will formulate and develop a model. The model must be

validated, and afterwards, which means he fulfills certain requirements (both content-wise and formatting), must be documented for future use. For attaining the highest efficiency of the simulation exercise, the virtual environment created must be similar to the external one, considered to be vital for the educational objectives set. So, having that in mind, in developing a simulation exercise, the experimental scenario/design/environment and experimental conditions for runs must be carefully selected in order to meet the criteria of similarity and thus, adding educational value to the exercise. The final steps focus on performing the actual exercises, collecting the results, interpreting them and offer a feedback support, in order to increase the efficiency and effectiveness of the exercise itself.

### 2.2 Experiential learning.

The general purpose of education is learning. So, how do the exercises based on simulations and virtual reality offer support and complements the traditional forms of education and training? The answer relies in the realities of today’s educational system. We are experiencing an educational landscape defined by the culture of one right answer. Requesting them to always have the commonly accepted answer (singular) does not allow them to truly learn. The information is distributed as input and the expected output is limited to replicating the initial information delivered by the teacher or instructor.

The dominant culture became the standard, and the students are indirectly encouraged by the system itself to follow routine algorithms rather than to raise question and use their curiosity and imagination. The educational system favors standardization to the detriment of a wide range of alternative and possibilities.

Experiential learning not only contextualizes the trainee’s experience in realistic environments, but also, during evaluation, does not seek to check the answers given on a predefined list of items, but to identify the decision-making mechanisms that determined the trainee to initiate certain actions. The trainees are exercising their freedom in a virtual environment – situated cognition. Learning by experience or in some



cases, by mistake, placing the individual under time pressure, simulating the conditions of a real-life mission can offer an authentic experience and a substantiated basis for learning. Ken Robinson explained during his TED speech (How to escape education's Death Valley) the premises for the human life to flourish. First of all, one must acknowledge the fact human beings are naturally different and diverse, and secondly, they are curious. Curiosity is the engine of achievement and for an efficient act of education; the teacher or the instructor must stimulate, provoke and engage his students. Curiosity, in most cases, acts as a force of self-motivation and determines knowledge. And this is exactly how simulation and modeling works.

### **2.3 Kolb Experiential learning model.**

Consistent with the constructivist learning theories (Vygotsky, 1978), according to which a learner builds his own knowledge, through experience while exploring the world and performing activities, David Kolb (1984, 17) has elaborated an experiential learning model, based on 4 main stages, which can explain the inherent educational mechanisms of simulation and modeling.

The stages identified by Kolb are concrete experience, reflective observation, abstract conceptualization and active experimentation, within which the individual moves from personal involvement to everyday situations to understanding the environment, learning the theories applicable to the system studied and finally, experimenting with changing situations. The traditional forms of education and training manage to properly deliver the theoretical basis for understanding a complex environment, but fail at engaging the trainee in the environment. And here is where simulation kicks in.

As Mel Silberman (2007, 8) stated, experiential learning can be based either on real experiences, or on structured experience that simulate or approximate real life. "Copying" realities and placing the student within the replica simulates the real-life

conditions, but still offers the possibility of a re-evaluation, thus understanding where errors occurred and how he should have encountered them, for a maximum of advantages.

However, although constructivism theories of learning claim learners build knowledge and meaning through their own experiences, Vygotsky (1978) considered this to be a debatable aspect of learning and focused on what he called Zone of Proximal Development, defining ZPD as the area or domain in which the learner cannot manage the inherent problems with a high level of efficiency, but can complete a task if supported by a more capable mentor (Kivunja, 2014). The activity of the student (or students, if the proposed exercise involves working as a team) is coordinated and supervised by the teacher, or the instructor in charge with the exercise, ensuring in this way the expertise of the information-delivery guy and outgrowing ZPD.

### **2.4 Experiential learning in the digital age**

Considering the fast-paced developments in technology and IT and based on constructivism theories, Prensky (2001) divided the learners in two categories, called Digital Natives and Digital Immigrants. The intelligence practitioners and decision-makers of the future are students of today, the educational methods should be adapted to their needs and motivation mechanisms and they are Digital Natives. Pursuant to consistent exposure to digital technology and devices (that have become an integrated part of their existence, even routinely), the digital generation has changed the way learners think and acquire information – they do not limit to the linear exposure offered by textbooks, but prefer searching engines that facilitate sorting the information, searching by keyword and underlining aspects of utmost importance. Hyperlinking information, they learn with technological support and assistance of games, wikis, blogs they create and/or access. Most of the times, children learn to use the computer

and obtain digital fluency before learning how to write properly. In *Teaching the Digital Generation* (Kelly, McCain, Jukes, 2009), the authors emphasize the fact Internet has given people power and learning has become dynamic, relevant and fun (13).

In order to obtain performance, efficiency and well-trained practitioners, the educators must acknowledge that education cannot be done in digital generation in a traditional manner.

Furthermore, the last-decade development in technology and software can provide simulation and modeling added value, through aspects that don't relate exclusively to hardware or software components, but also to computer graphics and human-computer interaction. The advances in the field offer a higher degree of similitudes between the real world studied and the virtual environment created for educational purpose.

### **3. SIMULATION AND MODELLING IN MILITARY ORGANISATIONS**

The traditional war has shifted from military to an asymmetric hybrid war. The paradigm shift imposed as a necessity the adaptation of the military organization to the realities of the international system and to the new concept of war. As an implicit consequence, the role of the military in the state architecture of defense modified. The multiplication of possible risks, threats, potential varment entities made them harder to detect, prevent and counteract. Considering the modern war no longer starts as a conventional conflict, my paper focuses mostly on intelligence organization. Hence, the performance indicators for future practitioners became higher. In the attempt to meet the new standards of performance and efficiency, the intelligence organizations have recently focused on the virtual reality exercises and serious games, products that are not destined to entertain the individuals, but which use entertainment (processes, techniques) to achieve an educational purpose.

Considering the specificity of the intelligence activity, "a good program should not only educate students by enabling them to learn how to think about and perform analyses, but it should also train them by teaching them the ethics, terminology, structures, processes, and pitfalls associated with the intelligence profession" (Lahneman, Arcos, 2014, xi). When discussing about intelligence, conversations revolve mostly specifically around acts of espionage and terrorism, ignoring perhaps the most important aspects in the field: collecting data and analyzing it. The final informational product will serve as a decisional support for policy-makers, hence the status quo, as presented, must comply with criteria of relevance, opportunity, objectivity and the projections made have to rely on objective facts. Gathering multisource data (HUMINT, SIGINT, TECHINT, OSINT, etc.) can, in the digital era, be a challenge for the untrained eye, due to the large amount of data available. The intelligence officer, put under time pressure, in front of a multitude of contradictory data, which directly impact the national security, must take a fast decision about what is real and what is not, how he should act in order to preserve the national values.

Simulation and modeling seek to transform this decision-making process into a rational one, in which variables are analyzed and decisions are taken, and not based "on guts". Basically, simulation and modeling in training future intelligence practitioners seek to provide a better decision-making process within their activity and to improve individual performance.

The process of teaching through simulation and modeling follows four steps: educate – train – exercise – assess, for attaining a high level of performance and efficiency. The training can focus either on individuals, or on a group that works as a team and the issues placed under discussion can either be related to operational aspects (source handling, gathering information, etc.) or to tactical or strategical aspects, which imply the interaction of multiple entities.

The advantages of this method of teaching in intelligence are multiple and rely





mostly on the specificity of the intelligence activity. Being a rather secretive and sensitive environment, intelligence does not represent a safe practice space for future officers. The consequences of an error in a real life intelligence case or situation are of magnitude to affect the national security, expose sources and alarm verment entities of the Service's intention to destructure their network. It is hard for an intelligence trainee to gather experience in a place where he is not allowed to make mistakes. However, simulation and modeling reduce the risk of experimenting with the real system and provides the trainee a space within he can act, rewind and evaluate his decisions.

The development of technology allow placing the student in highly realistic immersive environments, that replicate the real environments studied and that imply interaction with and within the environment and require collaboration and competition. The conditions for the simulation runs are never ideal, and the instructor/teacher is always in control being capable of inserting triggering events or objects that can modify the environment and can appear as "wild cards". In this way, he can evaluate the rapidity of the student in taking decisions in a limited amount of time and the reasons behind the decisions. Usually, regarding this method of teaching and evaluation is made peer-to-peer, which means that every student is closely supervised by an instructor, with whom he discusses every move possible in the environment and argues his decision. It is not a quiz or a simple ticking test – yes or no. Also, unexpected events or crisis and the response initiated by the student will help acquiring and information regarding procedures and processes necessary to be respected in the activity. Case studies, in the form of lessons learned in intelligence, can be simulate, thus the trainees observing the methods used, if and where they went wrong, how handling a situation can be improved in similar conditions.

By using virtual reality, the experience of the trainee is not limited to observing other's experience, but also he is given the opportunity to create his own experience by being actively involved within the environment.

In evaluating the trainees, the instructor does not have a correct answer, but rather sets a frame within which the decisions of the student will evolve in actions with multiple consequences. Rather than simply performing the action, the exercise focuses upon the decisional capacity of the trainee and upon his ability to efficiently manage in a timely-manner the negative outcomes of his decisions, in a way that does not affect the operative situation. Given the fact there are multiple possibilities for every moment of the game, the students must know the procedures, techniques and legal framework that allows him to act in a certain direction and be able to argue and sustain his position as being the most appropriate for the status quo given.

#### 4. CONCLUSIONS

Simulation and modeling are not to be used as a singular teaching method, but rather as a complementary approach to traditional forms of education. The trainees first understand the theoretical boundaries within which they act and simulation and modeling complete the educational cycle by offering them a real (or close to reality) experience that enables the understanding of most trivial aspects and fathoms learning.

Concurring the aspects presented above regarding experiential learning, there are few ideas that need to be emphasized:

First of all, individual acquires knowledge better through real experiences and structured events that simulate real experiences.

Secondly, we live in a technological era and we are the digital generation. Pursuant

to constant exposure to technology, software and IT, digital natives tend to respond better to non-traditional forms of teaching.

Last, traditional risks and threats multiplied and gained asymmetrical characteristics.

In matters of intelligence education, using virtual reality seems to be a necessity, considering the applied character of the activity. The fast-paced changes of the security environment impose a condition upon intelligence officers and practitioners: they must be able to adapt and take good decisions under time pressure. Simulation and modeling provides them multiple realistic environments in which these abilities can be developed. Beyond the specificities of the intelligence activity, that must be spliced to the variety of asymmetrical risks and threats (defined by uncertainty), in the educational process an important aspect must be taken into account and that is: the characteristics of digital native generation (today's trainees, tomorrow's practitioners and decision-makers). The educational process must be adapted to the needs of the learners and of the system itself and not the other way around.

## **BIBLIOGRAPHY**

1. Robinson, Ken, How to escape education's Death Valley, TED, 2013
2. Prensky, Marc, (2001), Digital natives, digital immigrants, MCB University Press, vol. 9, no. 5, 2001
3. Chung, C., (2004), Simulation modelling handbook: a practical approach, CRC Press
4. Kelly, McCain, Jukes, (2008), Teaching the Digital Generation, Corwin Press
5. Kivunja, (2014), Teaching, learning and assessment
6. Kolb, D., (1984), Experiential learning: experience as the source of learning and development, Englewood Cliffs
7. Lahneman, J., Arcos, R., (2014), The art of intelligence - Simulations, exercises and games, Rowman and Littlefield
8. Maria, A., (1997), Introduction to modelling and simulation
9. Moon, J., (2004), A handbook on reflective and experiential learning, theory and practice, Routledge, Taylor and Francis Group
10. Nișă, Cristian, (2011), Social Media și schimbările din Orientul Mijlociu, Revista Română de Studii de Intelligence, no.5
11. Silberman, Mel, (2007), The handbook of experiential learning, San Francisco: Pfeiffer
12. Vygotski, Lev, (1978), Mind in society: the development of higher psychological processes
13. Evgheny Morozov, (2011), Foreign Policy Romania no. 20/ January 2011



"HENRI COANDA" AIR FORCE ACADEMY  
FACULTY OF AERONAUTICAL MANAGEMENT  
ROMANIA

STUDENTS' INTERNATIONAL CONFERENCE AFASTUD 2015  
*Communicating Across Cultures*  
Brasov, 2<sup>nd</sup>-4<sup>th</sup> April 2015



"GENERAL M.R. ŠTEFÁNIK"  
ARMED FORCES ACADEMY LIPTOVSKÝ MIKULÁŠ  
SLOVAK REPUBLIC

## HYBRID GEAR UNMANNED GROUND VEHICLE BPPV - 01

**Filip Franó**

Department of Mechanical Engineering  
Armed Forces Academy of general Milan Rastislav Štefánik  
Liptovský Mikuláš, Slovak Republic

**Abstract:** *Hybrid drives are more and more used in the world. It may be a condition of waning oil and the increasing price of gasoline or diesel. Various known car factories therefore seek the path of cheaper and more efficient transport. The studies are because of that dealing with alternative sources and types of drives that could replace the current powerplant. These actuators achieve results that are desired in many directions. For most people, this is an important aspect when buying, renting or using different transport facilities and services.*

*In view of the above, I was inspired by the results and the progress of science today, and began to deal with alternative sources, respectively. drives. I get interested in the field of electric motors and innovation in the field of compressed air motors. I also can not forget to mention the classic internal combustion engine which is available almost anywhere. Some gasoline engines have an enormously good performance to others. The aforementioned parameters concern of the consumption, emissions as well as performance. But its effectiveness is not sufficient and desirable throughout its functional cycle. But back to the compressed air. Compressed air has delivered its availability, purity, price and features. This energy source has a great ability to recovery. These values are given the stringent emission standards and requirements of manufacturers and merchants, very affordable and enjoyable. This proposal offers specific modes and methods of using these different powertrain, which when properly processed with the built-programmed controller, proved the most effective use of selected engines. This would result in preventing the problem of low efficiency and the undesired characteristics of the powertrain. Using combination of energy sources by my proposals would reach very interesting values. Each of the mentioned motors have its shortcomings. I chose a combination of these types of powerplants because with proper use of positive each of them can cover their negative sites and features.*

**Keywords:** *Hybrid, electric energy, gas, compressed air*

### 1. INTRODUCTION

Currently are placed much higher demands on the environment, in particular reduction and dependence on petroleum product as diesel or petrol. In those circumstances, different teams

of developers, scientists and designers are to answer the question, what will be then, if there is no oil? Of course, oil is still on Earth, respectively. below it, yet enough. This issue would not be good to be ignored, because the refining and chemical industries, which

processes oil, they depend on other sectors or industries. In such cases, solutions are not known to replace the oil. Without oil, mankind hardly dispense. Given this fact, oil should be saved and if the situation demands it should use all available solutions to reduce the consumption of petroleum products as fuels. Due to these facts, various commercial as well as non-company engaged in the development of alternative hybrid drives. Some of the solutions I chose in this work too. I get interested in use of electricity and compressed air.

## **2. INTRODUCTION TO HYBRID GEAR**

The first vehicle, which was constructed with hybrid drive, was invented by the inventor of the first car with a combustion engine. In a short time was followed by a series-produced car, namely in the year 1910 car with the combustion engine and electric motors in the front wheel hubs. It was designed by Ferdinand Porsche. Vehicles were designed and produced by Austrian company Lohner. For unsatisfied battery capacity of the time, the car was not very applied. In 1969, Daimler gave the world the first hybrid bus. But the phrase 'hybrid' is not only combinational use of the internal combustion engine and an electric motor. It can be also the drive, which uses a combination of several sources of energy for propulsion. This may include various combinations, such as the internal combustion engine - electric motor - battery, fuel cell - electric motor - battery, combustion engine - and the flywheel and so on. The most widely used approach is the combination of an internal combustion engine – electric motor - battery. The main reason for the introduction of hybrid drives for motor vehicles is the low efficiency of internal combustion engines, about 30 to 40%. Classic and today the most widely used parallel hybrid system is in its mechanical essence a relatively simple. Internal combustion engine when cruising drives the vehicle and traction motor acts as a generator during braking. In the case of start-up or when accelerating, contributing its power to move the vehicle. While braking

or driving inertia is stored emerging electric voltage to the battery. It is known that internal combustion engines have the highest fuel consumption at start-up. When in this situation contributes with its high power traction motor powered by batteries, thus significantly reducing the fuel consumption of the internal combustion engine and exhaust leaving less harmful exhaust gases emissions into the atmosphere. Of course, electronics oversees the operation of the system. Modern concepts of hybrid drives still prefer the classic linking the internal combustion engine and wheels. The electric motor has a role to only help out in the transition state, which is appropriate to the internal combustion engine is shut down or limit its performance. For example, in traffic, when starting, braking. The next step is the placement of an electric motor directly to the wheel. Then, on the one hand, we get rid of the gearbox, transfer case, and we also obtain additional passenger and baggage space, mechanical losses will be reduced etc. On the other hand, for example, significantly increases the weight of the unsprung parts of the vehicle, thereby affecting the life of the body parts and performance. So much for the operation of the hybrid drive.

**2.1 How hybrid engines works ?** There are various combinations of connections of hybrid drives. The basic division is the construction of these motors in series or in parallel. To transfer torque and power from the engine to the wheels use various types of gears and other transmission mechanisms used for the transformation of energy. Ride of the vehicle may allow running of the engines in application of use of all engines or by one engine.

**2.2 Gasoline engines.** The gasoline engine is an internal combustion engine in an easily vaporizable liquid fuel, such as: natural and synthetic gasoline, kerosene, alcohol and benzene-petrol mixture. Gasoline engines work as a spark, igniting the fuel mixture is initiated by foreign sources.



Pic. 1 Gasoline engine

**2.3 Pneumatic engines.** These motors driven by compressed air from pressurized pneumatic pressure vessels using the network, followed by various valves and hoses to the pneumatic system of the engine which transforms the energy in cooperation with the structural components is transferred to the drive wheels that drive belts or wheels. Transformation of energy pneumatic motor can be realized in other ways.

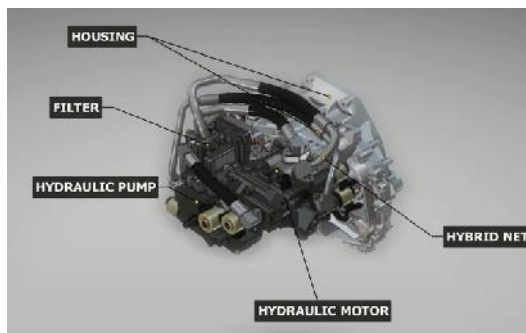

Pic. 2 Pneumatic engine

**2.4 Electric engine.** Electric motor is an electrical device which converts electrical current into mechanical work, respectively the mechanical movement - rotational movement (rotary engine) or a linear movement (linear motor). Opposite device to the electric motor is a device which converts mechanical work into electricity - dynamo and alternator. The

design of an electric motors and dynamos respectively alternator is very similar.

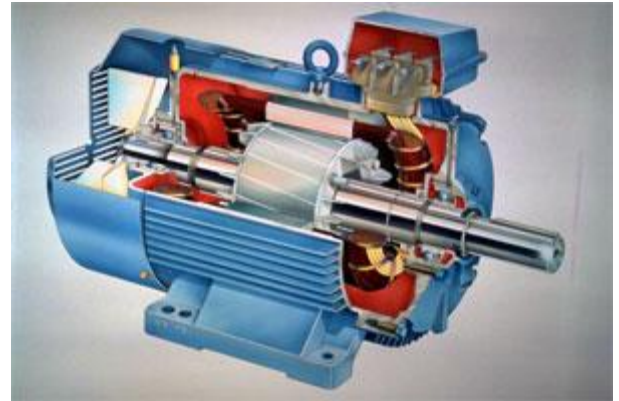

Pic. 3 Electric engine

### 3. UNMANNED GROUND VEHICLE BPPV - 01

In this chapter, I would like to present my solution proposed hybrid. This composition will be placed on tracked chassis, its energy is drawn from the battery with a capacity of 12 Ah, for the secondary branch, and actuate the primary branch, will use the compressed air to be compressed to 320 bar in pressure vessels deployed in the interior of the vehicle. Replenishment of pressure vessels will provide 3 piston compressor driven by a gasoline engine.

**3.1 Engine types in BPPV – 01.** Proposal for BPPV - 01 should consist of two-combination of two pneumatic motors in conjunction with two electric motors. This kind of hybrid should be classified as category "Air-Hybrid". I chose the alternative components with regard to their numerous advantages, which are listed at the end of my work.

**3.2 Gasoline section.** This type of engine in my proposal is designed to produce only the power required to drive the compressor, which would provide air compression to 320 bar in pressure vessels. For this kind of work I have chosen the following device. Stroke gasoline engine guaranteeing petrol in the tank, which

would be a calculated to twenty cycles of pressurization, which ensures long continuous driving.

Dimensions (length x width x height):  
890mm x 381mm x 483mm  
weight: 55kg  
Honda engine (power): 4,8 HP (petrol)  
Working pressure: 324bar (max)  
speed: 1200rpm  
Speed performance: 99l/min



Pic. 4 Gasoline engine used for working for air compressor

**3.3 Pneumatic section.** Section pneumatic motors BPPV - 01 should be the primary branch to propel the vehicle. I chose the engines considering their numerous advantages. These advantages include their efficiency, low consumption, adequate performance and power characteristics, acceptable noise levels and the possibility to provide motive power anywhere. These air units will draw its fuel source energy from pressurized tanks. These pressure vessels will be deployed in different parts of the application. Drive belts will provide direct mechanical transmission of torque from the engine to the drive wheels. Such mechanical transmission offers significant advantages.

I chose this type of pneumatic engine because of its variability. For different working pressures we can provide different performance and power parameters. In the basic working pressure (3 bar) is referred to 1.5 kW. If we widen the application working pressure to 12 bar, the engine should possess a

power of 18 kW. This information is stated by the manufacturer. Given the fact that this engine is the best possible solution for my application, because at different loads should give the necessary functional value. The total transmission power and torque to the drive wheel is secured by mechanical transmission.

Power: 1.5 kW (at 3 bar working pressure)  
Torque: 39 Nm (at 3 bar working pressure)  
Air consumption: 5 L / s (at 3 bar working pressure) Efficiency: + - 80%



Pic. 5 Quasiturbine – pneumatic engine

**3.4 Electric section.** As stated above, such machinery has to provide the drive power of the secondary branch of drive. As stated above, such machinery has to provide the drive power of the secondary branch. I chose two 300 W motors, which should draw electricity for its operation of the gel battery. The transfer of power and torque of the electric motor will be provided through a belt drive to a mechanical transmission with pneumatic motor.

**3.5 Control unit.** An important part of this hybrid should be efficient and reliable control unit. The controller should continuously decide on appropriate use, switching and electing from two types of variants of the engine. Of course there should be a proper recount and report endurance.



#### 4. VARIANTS OF USING AND INVOLMENT OF SINGLE SECTIONS

I decided to use the classical division use of engine, which was divided into three variants. Each mode has its advantages and location of use.

1. Basic mode.
2. Hybrid mode.
3. The secondary mode.

**4.1 Basic mode.** The basic scheme would include the function of running two pneumatic motors. The control unit should be asked to select the best solution for selecting the optimum working pressure engines with respect to resistance, which should the vehicle overcome. It follows that, in different situations and terrain engines would operate adjusted and it would provide maximum mobility, operational flexibility and good handling characteristics.

**4.2. Hybrid mode.** This scheme would have found its greatest application at maximum load, obstacles and resistances of the environment. Control unit for such conditions would turn on the hybrid system and the vehicle would be able to overcome various obstacles, terrain and under.

**4.3. Secondary mode.** This mode should have its largest application during production of compressed air into the pressure vessel. While it would not compressed air for pneumatic power engines, it would be taken care of propulsion and two electric motors.

**4.4 Chassis and body.** Chassis of the vehicle will be equipped with two drive wheels, one on each side, on the sides of the rear of the vehicle. These drive wheel will transmit power and torque on belts. Tensioning the belts will be provided by two idler wheels, one on each side of the roller at the front of the vehicle. The vehicle will be equipped with dampers that are attached to the

ten travel wheels. Above the traveling wheels are placed two supporting rollers on each side.

Body of the vehicle will consist of armor, which is resistant caliber 7.62 mm. In various parts of the vehicle will be different thicknesses and angles, inclinations shell due to ballistic protection. At the top of the hull is designed element of design which allows the application of various equipment and weapon sets for this vehicle.

Specific dimensions and materials are in the process of drafting and solutions to various requirements that are imposed on the design of the entire vehicle.

#### 4.5 Advantages of the device

1. Low power consumption.
2. Low emission production..
3. Large range and long time of continuous driving.
4. Gain competitive vehicle.
5. Prospective economical model.
6. Minor structural complexity.
7. The use of renewable energy sources in greater representation than fossil fuel = saving oil.
8. High throughput and operability.
9. High Performance.
10. The relatively low weight.

#### 5. CONCLUSION

Drawn from work can be concluded that the planned proposal has many positives and is comparable with conventional powertrains. The emphasis that has been placed on consumption, range and sufficient performance parameters, was filled. Emission products and reduction of the costs of running applications should also decreased rapidly towards down. Due to the flexibility of the pneumatic motor is guaranteed sufficient power and torque. The whole application is characterized by high throughput and mobility. Aim of the project tends to fill with with

relevant knowledge and sufficient quality production conditions.

## BIBLIOGRAPHY

1. BEDI, E. 1999. *Alternatívne palivá v doprave*. [online]. Bratislava : Fond pre alternatívne energie – SZOPK, 1999. [cit. 2012.03.15]. Dostupné na internete: <http://www.seps.sk/zp/fond/doprava/index.htm>.
  2. JANÍK, L.-DLOUHÝ, P. 2008. Jak se vyrábí palivo budoucnosti. Vodík pro auta i elektroniku. In *Idnes.cz*. [online]. 2008. [cit. 2012.01.20.]. Dostupné na internete: [http://technet.idnes.cz/jak-se-vyrabi-palivo-budoucnosti-vodik-pro-auta-i-elektroniku-p6d-tec\\_technika.aspx?c=A080127\\_234744\\_te\\_c\\_technika\\_vse](http://technet.idnes.cz/jak-se-vyrabi-palivo-budoucnosti-vodik-pro-auta-i-elektroniku-p6d-tec_technika.aspx?c=A080127_234744_te_c_technika_vse)
  3. VLK, F. 2004. *Alternativní pohony motorových vozidel*. 1. vyd. Brno : Prof. Ing. František Vlk, DrSc., nakladatelství a vydavatelství. 2004. 234s. ISBN 80-239-1602-5.
- VLK, F. [2004]. Alternativní pohony motorových vozidel. [online].*





## MEASUREMENT OF RADAR CROSS SECTION BY USING DOPPLER METHOD

Zsolt Kiss\*, Kristóf Fábíán\*\*

\*Military Engineering, Department of Military Aviation, National University of Public Service, Szolnok, Hungary, \*\* Military Engineering, Department of Military Aviation, National University of Public Service, Szolnok, Hungary,

**Abstract:** On 11 September, 2001 terrorists of al Qaeda hijacked several airplanes. By switching off the transponders of the airplanes they became invisible for the air traffic control. The transponder is a device that responds to the signal of the transponder radar on the ground.

However if the transponder is switched on an incorrect mode, or missed to be switched on it causes serious problems. When it works wrong the signal of the airplane appears only as a light point on the monitor of the air traffic control service without any flight data. It is unacceptable for the controllers. After the case the main aircraft companies began to investigate the structure of the radar cross section of the airplanes and created a database. By using this database it is possible to determine the type of the airplane. Although it is a great assistance for the air traffic control service but by the progresses of technology new composite materials appeared that have very different characteristics than their metal counterparts. With the use of these materials the radar cross section of the airplanes became quite different. As a consequence the mentioned database became obsolete.

In our essay, considering these facts, we intend to investigate the reflected signals of airplanes made of metal and composite.

**Keywords:** composite, Doppler effect, radar, radar cross section, RCS

### 1. INTRODUCTION

The advance of technology allows using more and more composite materials in aircraft construction. These materials have outstanding features, they are as strong as metal parts but much lighter. In the '90s the proportion of composites was about 10-15%. However in the newest Airbus A350, which made its maiden flight on 14.06.2013, this ratio was 50%.

Composites are made mainly with the integration of carbon and glass fibers, ceramic and plastic. When operating a plane it is an important fact that composites can be 20% lighter than traditional parts. It is more economical to run an aircraft made by composite. (Barton, Leonov, 1998)

Nevertheless carbon fibers have great conductivity and along with this they have big absorption factor, they dissipate electromagnetic waves.

From military aspects the reduction of RCS is vital, but quite on the contrary in civilian air traffic it causes problems. It diminishes the chance of detection of aircrafts. (DíazCharris, Torres, 2012)

### 2. MEASUREMENT OF THE RCS ISSUE

**2.1 Measurement with reflecting plates.** In order to get acquainted with the radar and the analyzer software before the mock-up plane measurements were carried out on small reflecting plates. As the structure of these plates is much simpler than the plane we

concluded that the evaluation of the reflected signals can be easily done.

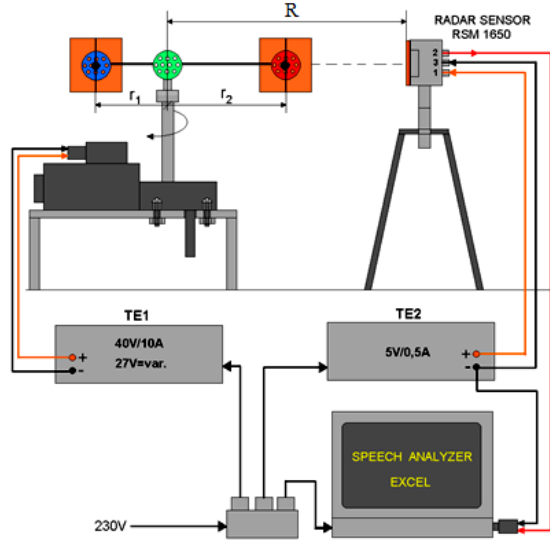

Fig.1 Measurement with reflecting plates

The reflecting plates can be seen on this figure moved monotonously in a circle around the drive axis with 18cm radius. The distance between the axis and the radar was 35cm. The side length of the plates was 2,5cm. The monotonous circle movement was provided by a rotatory mechanism driven by a 27V power supply. The output of the radar was connected to the soundcard input of the computer. To evaluate the reflected signals we used the downloadable free Speech Analyzer and the Microsoft Excel software.

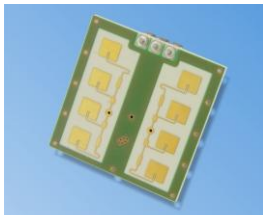

Fig.2 RSM 1650 Doppler radar

Our measurements were carried out by a RSM 1650 type Continuous Wave Doppler radar. This unit supplies an unamplified mixer signal, which must be treated in a subsequent amplifier before it can be evaluated by means of a comparator or a micro-controller. The functions mentioned were provided by the sound card of the computer.

In figure 3 we can see the disposition of the reflecting plate. The measurements were initiated in  $t_0$  moment and at  $0^\circ$  degree.

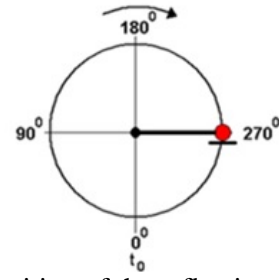

Fig.3 Position of the reflecting plate

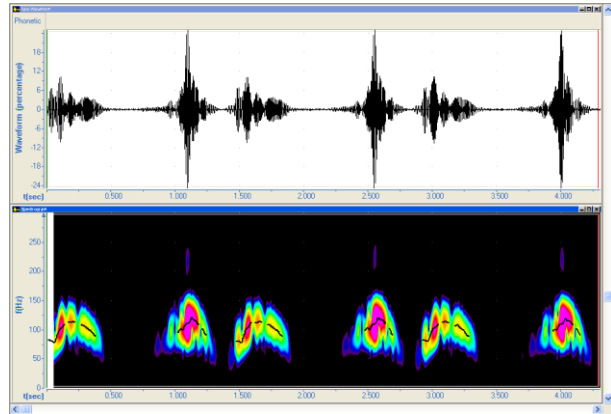

Fig.4 Waveform and spectrogram of one reflecting plate

In figure 4 we can see the Waveform and the spectrogram of the reflected signal. Watching the Waveform we can determine the phase of a circle as it can be clearly seen that it repeats periodically.

On the vertical axis of the spectrogram shows the frequency with respect to time. The curves in the colored areas indicate the average rate of Doppler frequency and that was recorded in Excel as Pitch value. The colors refer to the intensity of the detected signal, in dB. The redder the color, the higher the value of intensity.

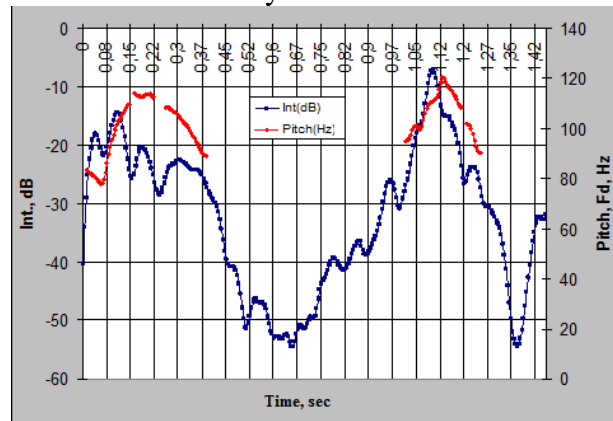

Fig.5 Intensity and Doppler frequency graph of one reflecting plate



On the vertical axis fig.5 shows the intensity (in dB) and the Doppler frequency (Pitch in Hz) of the reflected signal with respect to time ( $t = [0 - 1,42s]$ ).

Considering the features of the RSM 1650 it is important that it is unable to distinguish approaching and receding movements. It is quite well illustrated in fig.5 in interval  $t = [0 - 0,39s]$  as the intensity reduces, refers to receding movement, but the Doppler frequency increases. The Doppler frequency reaches its maximum, so do the radial velocity. In interval  $t = [0,39 - 1s]$  the rate of the average Doppler frequency is so low that it is not displayed by the software as it is below 20Hz. In the third interval  $t = [1 - 1,25s]$  the Doppler frequency rises simultaneously with the intensity. The intensity reaches its maximum, so the reflecting plate is approaching.

According to the description of the RSM radar its power is 16 dBm, compared to 1 mW:

$$16\text{dBm} = 10\lg \frac{P_t}{1\text{mW}} \quad (1)$$

$$P_t = 10^{\frac{16\text{dBm}}{10}} \cdot 1\text{mW} \approx 40\text{mW} \quad (2)$$

transmitted power.

By using equation no.2 we calculated the value of the reflected signal, given in dB, into mW power. This is illustrated in figure 6.

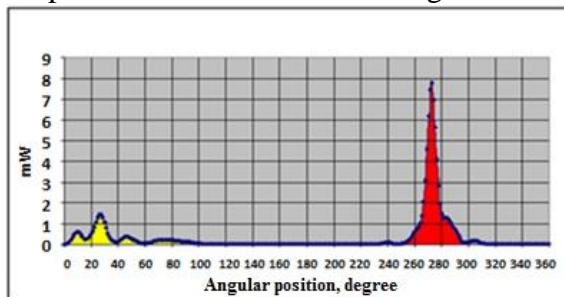

Fig.6 Power of reflected signal

The horizontal axis shows the angular displacement of the reflecting plate from 0° to 360° degrees. The power of the reflected

signal in mW is signed on the vertical axis. The figure on the left shows the angle position belongs to the maximal power, it is at 270°.

Taking equation no.3 into consideration we could draw the conclusion that the RCS is directly proportional to the intensity rate (in Watt). Fig.7 actually shows this relation, on vertical axis: RCS given in m<sup>2</sup>, on horizontal axis: the angular displacement. According to this graph the RCS of a 0,000625 m<sup>2</sup> reflecting plate is nearly 15 m<sup>2</sup>.

$$\sigma = \frac{P_r (4\pi)^3 R^4}{P_t G^2 \lambda^2} = 75,45 \frac{P_r}{P_t} [\text{m}^2] \quad (3)$$

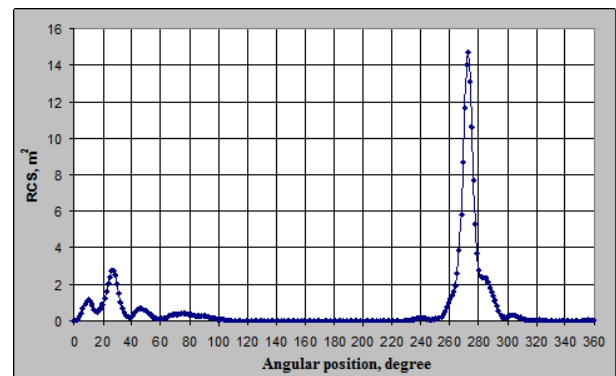

Fig.7 RCS graph of one reflecting plate in one revolution

Previously we described the measurement of the simple reflecting plates. As we see the evaluation of the signals is clear, we got to know with the software and the radar. The results prove that this concept is adequate to perform measurements with the mock-up plane.

**2.2 Measurement with mock-up plane.** The following measurements were carried out through the same method and logic as with the plates.

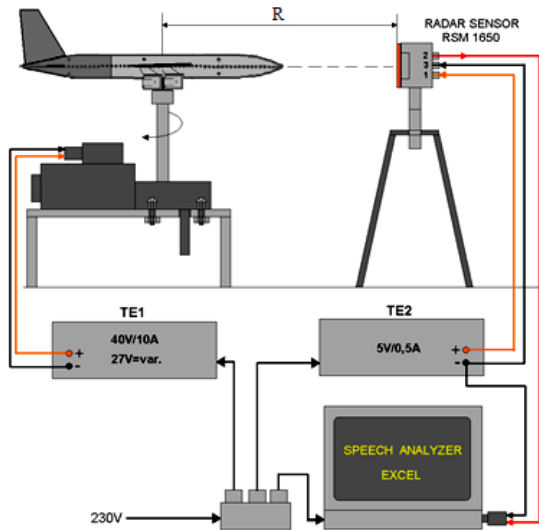

Fig.8 Measurement with mock-up plane

The drive axis was assembled with the plane at its center of gravity. The velocity was constant, measurements were started from  $0^\circ$ .

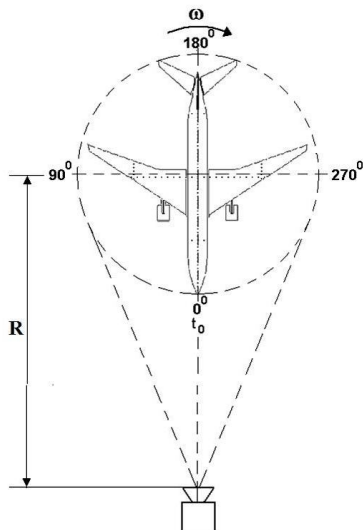

Fig.9 Measurement with all metal mock-up plane

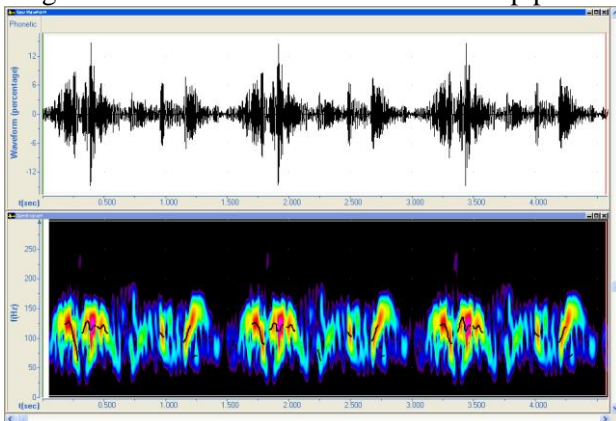

Fig.10 Waveform and spectrogram of reflected signal of an all metal mock-up plane

In fig.10 we can see that the periodicity of the signal still exists but it is more ambiguous. As a conclusion the more complex the sphere, the more fluctuating the waveform. In the spectrogram we can see the intensity and the average rate of Doppler frequency. However because of the elaborate structure of the aircraft it is more difficult to evaluate the signal compared to the reflecting plate.

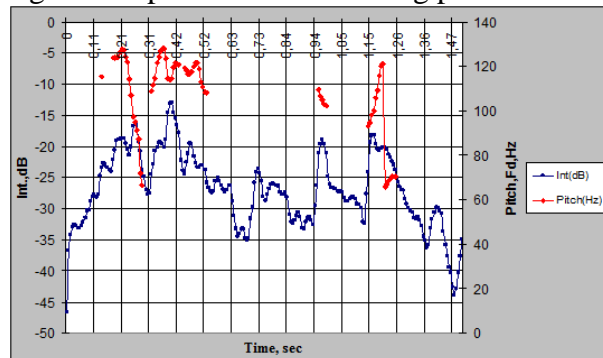

Fig.11 Intensity of reflected signal of an all metal mock-up plane

The rate of the Doppler frequency varies in accordance with the intensity. From fig.12 we conclude to the position of the moving object.

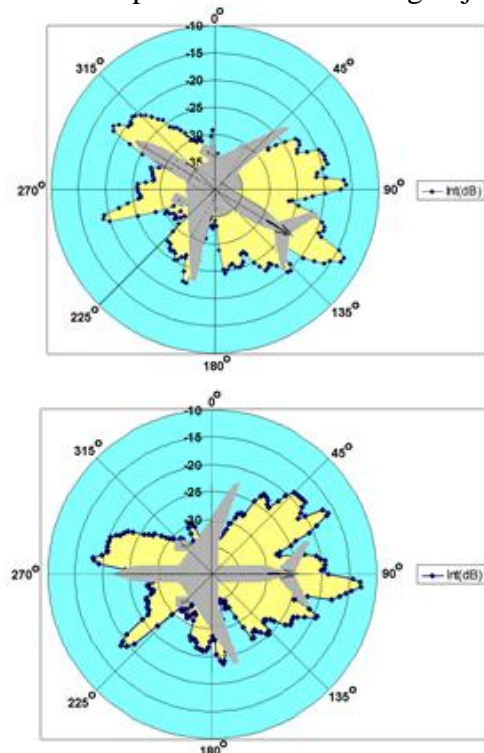

Fig.12 Intensity of reflected signal of an all metal mock-up plane in polar coordinate

Fig.12 shows measurements initiated from different angular positions. The planes refer to



the starting positions and the detected intensity rate is also shown in polar coordinate.

It is clearly seen that the structure of the signal is the same they distinguish only in the angle between the two starting positions.

Using the same calculations as at the reflecting plates we got fig.13 where the RCS is represented in function of angular displacement.

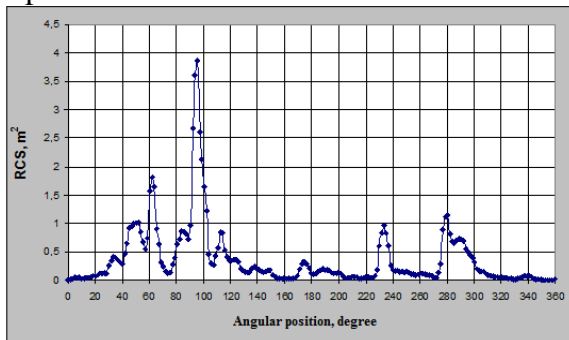

Fig.13 RCS of an all metal mock-up plane

We can obviously determine that the highest value of RCS ( $4\text{m}^2$ ) was at  $95^\circ$  degrees. In this moment the longitudinal axis of the airplane is perpendicular to the radar and the tail fin is approaching to the radar as well.

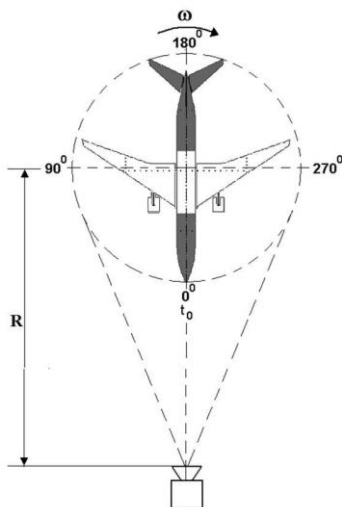

Fig.14 Measurement with composite nose and tail mock-up plane

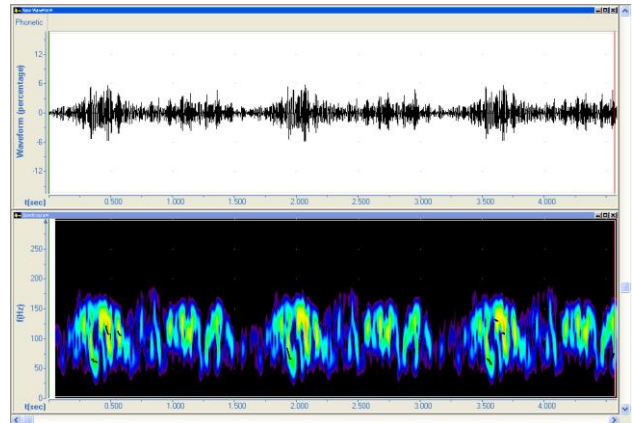

Fig.15 Waveform and spectrogram of composite nose and tail mock-up plane

As compared fig. 10 to fig. 15 we can observe that the amplitude of Waveform is greatly attenuated and the red areas, that referred to high intensity values, disappeared. Only light blue and green areas remained showing low intensity rates. Moreover the average Doppler frequency is also reduced.

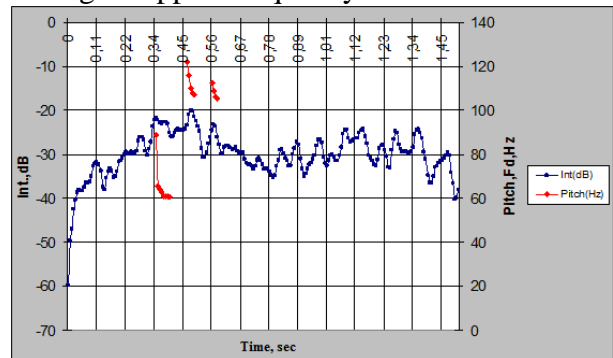

Fig.16 Intensity and Doppler frequency graph of composite nose and tail mock-up plane

As in this case only the middle of the fuselage and the wings are covered with metal the intensity of the reflected signal is rather low. Because of the horizontal circular movement of the airplane the big surface of the wings is irrelevant. The radar notices only the leading and trailing edge of the wings. The reflected signal coming from these surfaces is minimal as the polarization of the transmitted signal is vertical. Regardless of these facts

main reflecting surface is still the fuselage as it can be seen on fig. 17.

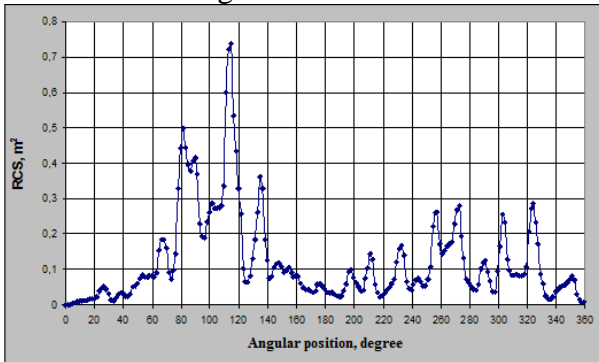

Fig.17 RCS graph of composite nose and tail mock-up plane

Although the structure of the RCS seems to be more fluctuating because of the change in the scale of the vertical axis, we can observe that the maximal RCS is less than  $0.8 \text{ m}^2$ .

### 3. CONCLUSIONS

The measurement results clearly show that the problem described in the beginning of the paper does exist, not just in theory but also in practice. As the measurements went on we continuously increased the composite surfaces step by step. By comparing the results we can

clearly observe that the detectability of the aircraft decreased. Alongside with it the RCS and the rate of the Doppler frequency also cut back. As composite materials have beneficial features they will be more widespread in aircraft construction with the development of technology. According to our results and evaluation the use of composite materials will cause detection issues for the air traffic control in the crowded sky of the future.

### BIBLIOGRAPHY

1. David K. Barton, Sergey A. Leonov(1998). *Radar Technology Encyclopedia(Electronic Edition)*. City: Boston, London  
Available:<https://selasl.files.wordpress.com/2011/08/artech-house-radar-technology-encyclopedia.pdf>
2. Vladimir DíazCharris, José Manuel Gómez Torres, (2012). *Analysis of radar cross section assessment methods and parameters affecting it for surface ships*, Available:<http://www.shipjournal.co/index.php/sst/rt/printerFriendly/72/250>



## ANALYSIS OF NETWORK COMMUNICATION USING FPGA

**Michal Kováč, Michal Turčaník**

Department of Informatics  
Armed Forces Academy of General Milan Rastislav Štefánik  
Liptovský Mikuláš, Slovak Republic

**Abstract:** *Packet analysis is one of the most common methods used today to determine and analyze network problems. The aim of this paper is to analyze communication in a packet-switched computer network using an FPGA board. The research platform was composed of two main parts – Virtex 5 programmable FPGA board and a program running on a computer. The board was used to sniff packets traveling over the network in order to record various statistical data. The software was used to communicate with the board and to collect the evaluated packet data. The data was collected in two sessions. The first session monitored student traffic and recorded over 1,6 million packets of varying types. The second session monitored controlled traffic and recorded over 160 thousand packets, mostly HTTP. The research serves as a starting platform for future application in hardware packet filtering used in firewalls.*

**Keywords:** *packet filtering, hardware, FPGA, HDL, firewall*

### 1. INTRODUCTION

Packet analysis, also called packet filtering, is a method of reading packet header data and deciding on further action based upon the values of each byte. This paper aims to utilize this method in a hardware solution and to analyze different types of packets traveling over an Ethernet network.

The first section explains what packet filtering is and how it operates.

The second part details the hardware of our research platform, which consists of a programmable FPGA board. It also describes the HDL implementation used to define the board's behavior and the computer software we used to control and communicate with the board.

After that, we illustrate the analysis of network communication in a computer classroom using our research platform.

Next, we present the results we gathered during two monitoring sessions, one with duration of 5 hours 33 minutes and the other lasting 15 minutes.

Finally we discuss the results and possible future applications.

### 2. PACKET FILTERING

**2.1 What is packet filtering?** Packet filtering, also known as packet inspection, is a method of reading the header of a packet and using this data to either drop the packet or let it pass through. It is most commonly used in basic hardware firewalls, as a part of a router or a dedicated firewall appliance, operating on the second and third OSI layers and partially on the fourth.

This paper focuses on static filtering. This type of packet filtering uses only data found in currently analyzed packet itself, it does not take into account data found in previous packets. This means that the filter is unaware of existing connections or streams and decides on each packet individually. Therefore, they are called stateless firewalls.

Advantages of stateless firewalls are low memory requirements, speed and low latency. The main disadvantage is that they cannot

make more complex decisions based on the state of communication. Therefore, their best use is in filtering stateless network protocols such as IP or HTTP.

**2.2 Operation.** Packet filter works in a very straightforward manner. It compares each of the packet header field values with the predefined rules and decides whether to discard or forward the packet, as shown in figure 1.

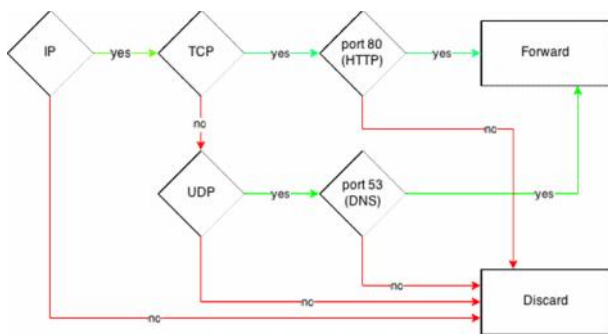

Fig. 1: Packet filter flowchart

Packet filters make decisions based on the following information: network layer protocol, source IP address, destination IP address, source port and destination port.

Allowing a certain field value does not necessarily mean that packet will pass through. For example, a filter may forward packets on port 443 (HTTPS), but only if their protocol is TCP. On the other hand, it may drop the packet from a different port, even though it uses an otherwise allowed protocol (TCP), as shown in figure 2.

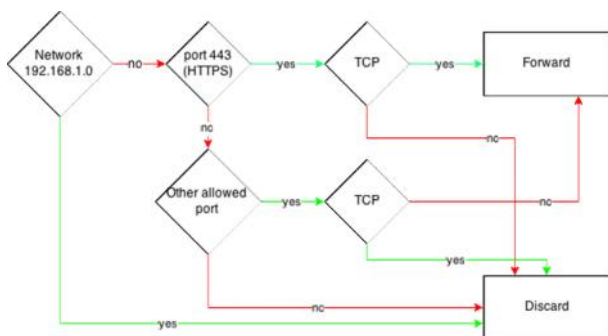

Fig. 2: Packet filter flowchart

**2.3 Packet filter application.** One of the specific uses of packet filter is to block inbound traffic from an outside network, also

known as ingress filtering. Hardware implementation makes it faster and reduces the traffic that software firewalls have to handle. For example, if an inside network does not provide DNS services for the outside, the filter can block all the DNS requests coming from outside in, reducing the load. This method can also be used to block all unused ports and therefore increase security.

Another use of packet filter is egress filtering, which filters traffic coming from the inside. It is the usual method of allowing only certain services to users on the network, for example “allow only HTTP and mail, block everything else”.

Both filtering methods are recommended in protection against denial of service (DoS) attacks, as specified by RFC2827.

### 3. RESEARCH PLATFORM

**3.1 The board specification.** The first part of our research platform is a Virtex-5 family FPGA board. An FPGA is an integrated circuit designed to be programmed by a user in order to perform a wide variety of functions, such as memory processing, cryptology, arithmetic, digital signal processing, video processing, ECC and many others.

Our research is built on a XILINX ML505 evaluation platform, which on top of the Virtex-5 FPGA consists of many other functional parts and components.

ML505, among others, includes these components: 256MB DDR2 SODIMM, 550MHz programmable clock generator, general purpose LEDs and buttons, JTAG configuration port, AC97 audio codec with SPDIF digital output, RS-232 serial port, 32 character LCD display, PS/2 mouse and keyboard connectors, VGA video input, DVI video output, 32MB flash chip, 10/100/1000 tri-speed Ethernet transceiver with RJ-45 interface, USB interface chip and ports, temperature and voltage monitoring chip, PCI Express and SATA connectors.

The FPGA itself (codenamed XC5VLX50T as shown in figure 3) uses a MicroBlaze embedded processor, which is an RISC optimized by XILINX.



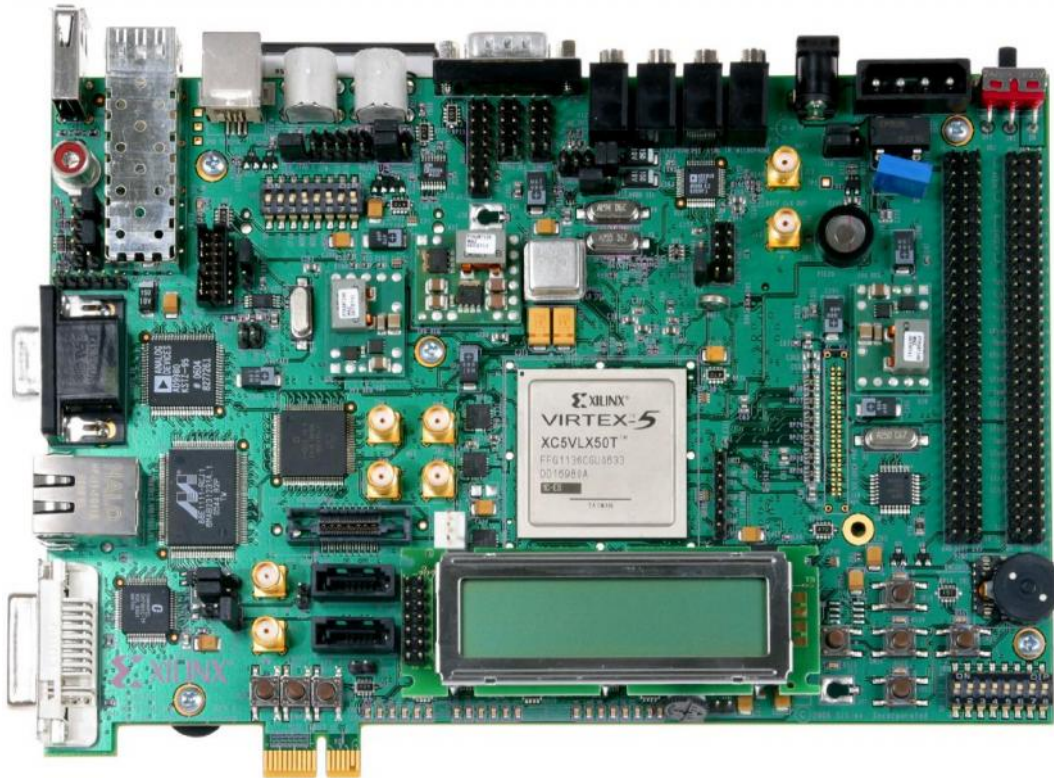

Fig. 3: ML 505 Evaluation Platform

**3.2 HDL implementation.** The FPGA runs our modified version of *Virtex-5 Embedded Tri-Mode Ethernet MAC Hardware Demonstration Platform*, which is an app codenamed *xapp957* created by XILINX to demonstrate the board's Ethernet functionality.

The Ethernet is run by a MAC wrapper core generated by the XILINX CORE Generator and consists of the following components: Tri-Mode Ethernet MAC primitive, FIFO, clocking logic and a GMII.

The microprocessor is based on a MicroBlaze v7.10d processor and a PLB-based subsystem containing 16kB RAM, UART, interrupt controller, GPIO and custom peripherals for connecting the MAC, as shown in figure 4. It runs software, written in C programming language, which monitors the serial interface for commands given by our PC application. On startup, the software configures the board with default settings and awaits further commands from the user.

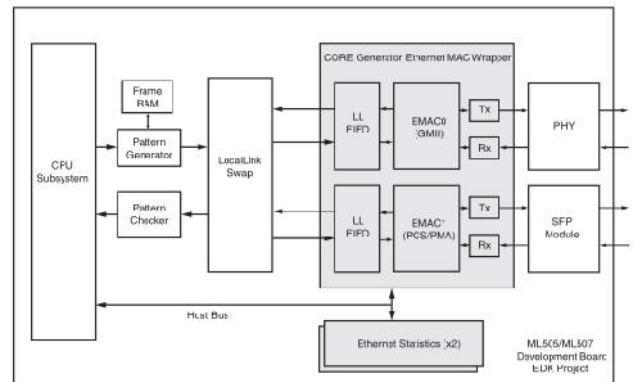

Fig. 4 FPGA Ethernet MAC block diagram

**3.3 Computer software.** Our PC application is written in C# programming language. It sends commands over a serial port in the form of bytes, each combination of bytes representing a different command. The first byte 0xAA means that the following byte will be a command. For example, 0xAA97 is to flush the FIFO, 0xAA98 is a command to read the FIFO and 0xAA99 is to send the current collected statistics to the PC. The byte

sequence is followed by a CRC-32 of that sequence to ensure the integrity of the transmitted data.

The process we used to collect the statistical data from the network is as follows: first we issue the “read FIFO” command, which puts the board in a loop, continuously reading the FIFO buffer. Each read examines the data needed to filter the packet, as examined in chapter 2 of this paper. Currently, the data is examined for statistical purposes only – no actual filtering is done by the board. To read the current statistical data, we issue a “send statistics” command. To finish, we issue a “stop reading FIFO” command.

**3.4 The setup.** The whole research platform was setup as shown in figure 5.

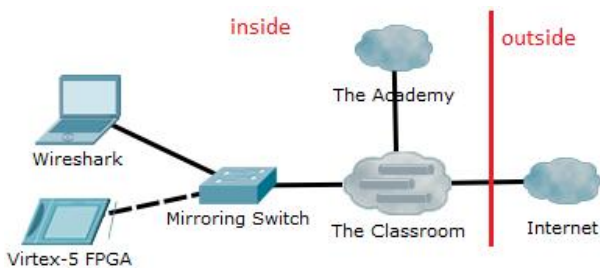

Fig. 5: The setup of our research platform

The computers in the classroom were connected to the academy network and to the Internet through a proxy firewall. All the traffic coming in and out of the classroom was sent to our Cisco 2960 switch, which then mirrored it to both the FPGA and the computer. The FPGA analyzed packet headers only. The computer was running Wireshark packet sniffer to collect information such as packet size or average bitrate.

## 4. DATA COLLECTION

**4.1 The filtering algorithm.** In order to collect the statistical data from the network, we must analyze each packet using a predefined algorithm. First, we created a list of actual protocols and IP addresses we wanted to look for. Then we implemented this algorithm into the C code executed directly by the FPGA. We used a series of *if* statements to examine specified bytes within each packet header. If the byte matched any of the

conditions, the respective counter was incremented.

The first information we examined was the network protocol. We divided them into TCP, UDP, and “other protocols” groups. Next, we looked at the source port. We counted the packets for these ports: 25 (SMTP), 53 (DNS), 80 (HTTP), 110 (POP3), 443 (HTTPS), 67 (DHCP server), 68 (DHCP client) and 3389 (RDP), as shown in figure 6.

```

if      (buffer[39] == 0x19)  { SMTP++; } //25
else if (buffer[39] == 0x35) { DNS++; } //53
else if (buffer[39] == 0x43) { DHCPs++; } //67
else if (buffer[39] == 0x45) { DHCPc++; } //68
else if (buffer[39] == 0x50) { HTTP++; } //80
else if (buffer[39] == 0x6E) { POP3++; } //110
else if (buffer[39] == 0xBB) { HTTPS++; } //443
else   { other_port++; }

```

Fig. 6: Network protocol analysis

If the source port didn’t match any of these, we applied the same group to the destination port. If the destination port was not matched, the packet was recorded as “other ports”. The source IP was not examined, since we collected data for the network as a whole. The destination IP was divided into two groups: “inside” for packets with destination inside the academy network, and “outside” for packets destined outside of our network. The data was recorded in the form of integer variables and retrieved using a specific command, as shown in figure 7.

```

case CMD_SEND_STATS:
    XUartLite_SendByte(XPAR_RS232_UART_BASEADDR, (Xuint8)(TCP >> 24));
    XUartLite_SendByte(XPAR_RS232_UART_BASEADDR, (Xuint8)(TCP >> 16));
    XUartLite_SendByte(XPAR_RS232_UART_BASEADDR, (Xuint8)(TCP >> 8));
    XUartLite_SendByte(XPAR_RS232_UART_BASEADDR, (Xuint8)(TCP));
    XUartLite_SendByte(XPAR_RS232_UART_BASEADDR, (Xuint8)(0xBB));

```

Fig. 7: Part of the “send statistics” command

We recorded data in two sessions and then we analyzed the results.

**4.2 The collected data.** Our first session lasted 5 hours and 33 minutes, out of which approximately 2 hours were traffic-heavy. The rest of the time, traffic was mostly idle, with computers sending only periodic requests and broadcasts. This session monitored student’s traffic during a lesson and was not influenced in any way.

We recorded exactly 1 631 129 packets with average size of 648 bytes. A surprising



85% of those packets were TCP, with only 6% of UDP and 9% of other transport protocols. As our academy network is behind a proxy firewall, which requires all outgoing traffic to be directed to a specific port, it is impossible to determine the application layer protocol for packets with destination outside the firewall. However, since the firewall permits mostly just HTTP and HTTPS, it can be determined that all outgoing traffic is for one of these two protocols. Therefore, only 0,3% of traffic was explicitly directed to HTTP inside the network, which consists of our academy web page and an intranet portal. However, the share of packets traveling inside the academy network was 63%, which is attributed mostly to the RDP protocol (41% of packets). This protocol is used for the remote desktop connection which students use to connect to a courseware server. Outside-traveling packets formed 36%, which together with 7% share of DNS packets suggests a lot of internet browsing.

Our second session lasted 15 minutes, during which 3 computers were constantly sending and receiving packets. The first computer was used to watch multimedia content, the second was connected to a remote server using RDP and the third was browsing the internet and sending e-mails using POP3 and SMTP.

We recorded a total of 160 829 packets with average size of 822 bytes. As expected, most of those packets were destined outside the network (74%) and due to heavy bandwidth requirements of multimedia content, as opposed to regular browsing, the HTTP protocol formed 88% of the total traffic. Even though one of the three computers was used solely for remote desktop connections, RDP protocol traffic formed only 11% of all packets. Again, TCP had a huge advantage with 93% when compared to only 2% share of UDP.

## 5. CONCLUSION

In this paper, we analyzed network communication using an FPGA board during several sessions. We found out that even if various network services are used equally, most of the traffic is attributed to the HTTP protocol. This is a direct result of bandwidth requirements of file and media sharing as opposed to e-mail, DNS or DHCP protocols, which require only a small amount of low-size packets. During a study-oriented network usage, 36% of packets were HTTP and in a browsing-oriented session it was an overwhelming 88%. The second most demanding protocol was RDP, with 41% share in the first and 11% share in the second session.

When comparing transport layer protocols, TCP had a large advantage in all sessions, making up approximately 90% of traffic in both sessions.

The next step of our research would be to orient the study in a different type of network, such as a home network, where there is a large amount of file and media content downloading. Other options include a public network, such as internet café, or a corporate network, where we could find a large variety of different protocols and services used.

Another improvements we want to make are better hardware implementation and a more effective resource usage, making the whole packet analysis process on the FPGA much faster, allowing us to get more accurate results. If the board could achieve 0% packet loss, the design might be implemented as a packet filter firewall or as a device for deep packet inspection.

## BIBLIOGRAPHY

1. Strom, D. (2002). The Packet Filter: A Basic Network Security Tool. *Global Information Assurance Certification Paper*. [online]. Available: <http://www.giac.org/paper/gsec/131/packet-filter-basic-network-security-tool/100197>

2. Ferguson, P., Senie D. (May 2000). Network Ingress Filtering: Defeating Denial of Service Attacks which employ IP Source Address Spoofing. *RFC2827*. [online]. Available: <http://www.rfc-editor.org/rfc/rfc2827.txt>
3. XILINX DS100 Virtex-5 Family Overview. (February 2009). [online]. Available: [www.xilinx.com/support/documentation/data\\_sheets/ds100.pdf](http://www.xilinx.com/support/documentation/data_sheets/ds100.pdf)
4. ML505 User Guide. (May 2011). [online]. Available: [http://www.xilinx.com/support/documentation/boards\\_and\\_kits/ug347.pdf](http://www.xilinx.com/support/documentation/boards_and_kits/ug347.pdf)
5. Virtex-5 Embedded Tri-Mode Ethernet MAC Hardware Demonstration Platform. (October 2008). [online]. Available: [http://www.xilinx.com/support/documentation/application\\_notes/xapp957.pdf](http://www.xilinx.com/support/documentation/application_notes/xapp957.pdf)



"HENRI COANDA" AIR FORCE ACADEMY  
FACULTY OF AERONAUTICAL MANAGEMENT  
ROMANIA

STUDENTS' INTERNATIONAL CONFERENCE AFASTUD 2015  
*Communicating Across Cultures*  
Brasov, 2<sup>nd</sup>-4<sup>th</sup> April 2015



"GENERAL M.R. STEFANIK"  
ARMED FORCES ACADEMY LIPTOVSKY MIKULAS  
SLOVAK REPUBLIC

## IS THE RUSSIAN FEDERATION A SMART BEAR?

Tiberiu LAZĂR, Codruț GHINEA

„Mihai Viteazul” National Intelligence Academy, București, România,

**Abstract:** *The essence of the 21<sup>st</sup> century is marked by the fluid security climate, the changes that have occurred at international scale and the dynamics of threat phenomenology, all of which determined a reconfiguration in the Balance of Power system. Inside this architecture, a reborn state, the Russian Federation, finds itself in a struggle of regaining its lost position, that of a global power.*

*The purpose of this paper is to determine whether the Russian Federation possesses the strategic vision, the managerial means and the modus operandi that are necessary for it to be a competitive state at a global scale. As a result, the analysis inside the paper reflects its capacity of functionally integrate soft power and hard power into a fully functioning smart power, as a means of promoting the state's national interests.*

*In order to do this, the research is based on two studies on specific situations that enlighten certain capabilities of the Russian Federation, together with a broader image of the perspective that the Russian Federation has to be a smart state. This broad image is generated by applying a technique that ensures the objectivity of the conclusion, the Analysis of Competing Hypotheses, the scientific approach guaranteeing the value of the answer to the question Is the Russian Federation a smart bear?*

**Keywords:** *security climate, international relations, power, state policies, intelligence, soft power, hard power, smart power*

### 1. INTRODUCTION

Since previous ages, the human being got to know, even though not theoretically, but only practically, what power means and how it is used or what it implies for the ones who possess it. The individual's capacity of reflecting over the manner in which the state acts in the regional and global connexions framework determined the birth of various thinking schools which look towards the international relations differently.

In the above mentioned dimension we are able to find two of the major schools that conduct the scientific initiatives of interpreting the manner in which states act and might act. On the one hand, we must take into consideration realism, a school that bases its theories on the idea that a state is able to

achieve its objectives in foreign affairs by using force, violent instruments, military means, all of which are known as 'hard power'. Realists consider that the international scene is governed by anarchy, harshness and competitiveness, and consists of state actors. Thus, in order to preserve a balance of power between these entities, the only means available is the military power and its utility in achieving national interest (Nye, 2004:5).

On the other hand, a second school from the perspective of adherence and importance, is represented by liberalism. Its promoters consider that in order to fulfill the national strategies, decision makers must refrain from using any type of violence. The balance of power, from liberalist point of view, can be preserved by creating and fostering links and connexions between states and other entities,

links that can be cultural, economic or of any other type, but not military. Thus, a concept was released in order to compress all these means of achieving objectives through means that are not violent: soft power (Doyle, 1986:3).

Applying a retrospective analysis, we can come to the conclusion that the manner in which the international environment configured in the previous decades created the premises of the two types of power above mentioned to manifest and be used by actors. But the characteristics of the 21<sup>st</sup> century brought about changes in the whole spectrum of actions and attitudes, from the level of the individual to the state-level. Hard power or soft power cannot guarantee success by being used alone in today's world. Thus, the necessity of connecting them and using them in an integrated way generated a new concept, the one of smart power – the ability of combining violent and non-violent means available for a state in order to promote and reach its objectives on internal and external level. (Nye, 2008:12)

## **2. THE BIG RUSSIAN BEAR DREAMING TO BE KING OF THE JUNGLE**

Recent times have brought into the world's attention numerous changes and actions of power balancing on the international field. In this context, the Russian Federation have represented and still represents a point of major interest for scientists, analysts and policy makers, because it started to recreate a certain image for itself, it started to build a new and genuine road towards becoming one of the big powers on the Globe.

In order to understand its desire and their manner in which chooses to act in order to achieve its goal, the paper offers the main elements that dictate the policies and strategies adopted by Russian decision makers of different areas.

The first major aspect that influenced the way in which Russians look towards other actors in the international environment is represented by the feeling of insecurity, the idea of constantly being the target of certain direct threats. This feeling was based back in

the first millennium, when the history offered the world a new-born entity: the Kievan state. Since its creation, and through its evolution towards Russian Empire and Soviet Union, Russian people had faced numerous waves of migrators and violent armies of other states – such as the Mongols – ending with the disintegration of the Soviet Union, an aspect which brought about a risk over preserving social unity, territorial integrity and facilitated a series of separatist moves with a certain impact on the national security of Russian Federation (Eitelhuber, 2009:5). This permanent fear and insecurity feeling determined the Russians to choose a realist approach towards the international relations, considering that the use of hard power inside the anarchy would ensure the state's capacity to preserve security and achieve its objectives.

A second element that deserves attention because it functions as fuel to some attitudes of today's decision makers in Russia, is represented by the big power status. Since the start of the expansion to East, during Ivan the Fourth rule, Russian people spent resources and lives in order to gain the status mentioned before, managing to do this in 1815, within Vienna Congress (Iver 2007:2). The idea of being a voice that every people in the world looks up to, was fostered during the Soviet period, as USSR was one of the two actors that dictated the manner in which the balance of power functioned.

Taking into consideration the driving factors that generate a certain strategic approach for the Russian Federation, we must also take into account the dynamics of the international relations and actors in the 21<sup>st</sup> century. The beginning of this age took Russian Federation closer to the rhetoric it used in the Cold War, because of certain factors: the expansion of NATO towards East, US presence in Central Asia within their missions against asymmetrical threats (Ermarth 2006:3).

Consequently, as the motivations and attitudes have been presented, in the following chapters the paper tries to determine the manner in which the Russian Federation used soft power and hard power in the 21<sup>st</sup> century



and its capacity of integrating them into a fully functioning and competitive smart power.

### 3. REFERENCES RUSSIAN BEAR'S QUALITIES

#### 3.1. THE KINDNESS OF THE BEAR

The following chapter focuses on the way in which the Russian Federation used non-violent means in order to achieve its geopolitical and economic goals concerning a specific area: Crimea. The analysis concentrates on the use of soft power in creating, maintaining and consolidating the separatist move inside this zone, with a view to finally attaching Crimea to the Russian Federation.

A first element that was used, from the soft power point of view, was represented by the activities developed by the 642<sup>nd</sup> group of GRU for Psychological-Informational warfare, a group present along with the Black Sea Russian Fleet stationed in Crimea. Using specific methods and techniques, the Ukrainian Intelligence Service generated a report that revealed this group's main mission: developing the necessary influence of Russian Federation over the socio-political situation in Crimea, through intelligence collection and propagandistic actions oriented against the national unity and towards a feeling of adherence to the Russian values and culture (Roslycky 2011:303).

A second element used in order to project a soft power in the region, was represented by the Black Sea Branch of Moscow University, situated physically inside a Russian military base in Crimea since 1997. Beside the location that permits Russians to control the human traffic in and out of the university, the impact of the Russian origin over the courses is a relevant aspect. Through this means, the ones that attend courses inside this university were taught and got used to thinking like a Russian person, interiorize Russian values and, consequently, develop actions that promote

Russian interests (Roslycky 2011:306). The first faculty, the one for Administration and Public Affairs, offers the human resource who occupies several positions inside the Ukrainian administration. By positioning individuals who promote Russian interests in local and central administration and in public institutions, the Russian Federation enabled itself to control the process of elaborating and implementing public policies inside Ukraine. The second faculty, journalism, in fact the only higher education institute for future journalists in Ukraine, generates the voices that will present the environment and will conduct people's opinions through media. The Russian Federation manages to train numerous journalists who will present the situations that will encounter in the manner in which they want to be presented, offering a perspective that will be close to Russian interests and way of reflecting towards a situation.

Another element of soft power used by Russians inside Crimea was represented by the NGOs that are financed, sustained and used by the Federation in order to fulfill their plan in the region. One example is the Russian Community of Crimea, an NGO that reunites 25 different organizations and 15.000 members. Having the support of the Russian Federation, people from this NGO managed to get important positions inside the administration, where they acted in order to facilitate the achievement of Russian objectives: in 2006, the NGO's leaders were elected in the Ukraine Parliament and, in 2009, 13 out of 17 members of the Simferopol Local Council were the NGO's members. The choice of using this means is fully rational, because the non-violent activities, hidden behind humanitarian goals of the NGOs, didn't attract a negative attitude from other actors in the world and also enabled the Russian Federation to influence the process of decision inside the Ukrainian state.

Another soft power manifestation was the policy of passports, a technique broadly used by the Russian Federation inside former Soviet

republics. This policy means that Russian authorities lower the requirements for gaining Russian citizenship for the people inside this areas, in order to increase the number of Russians. Moreover, by taking into consideration the international law, every state has the possibility and obligation to protect its citizens inside the country and abroad. Thus, by applying this policy inside Crimea, the Russian Federation assured itself that, in case of the failure of non-violent measures, it had the means of intervening with the army, for protecting the rights and fostering individual security for their citizens (Roslycky 2011:311).

But we must bear in mind the fact that these soft power techniques were used in Crimea in order to consolidate the separatist move. On the other side, Russian values and way of life is not looked up onto by Western civilizations, by the Middle East or by Asia. Consequently, the impact of these methods is present only in the ex-Soviet republics, but in other geographical areas not, driving the scientific approach to the idea that the Russian Federation is capable of using a limited soft power, not a globally functioning one.

Categorie	Descriere	Cod	Evaluare		
			1	2	3
D1	Prezenta o strategie explicită de aplicare a puterii moi în scopul realizării obiectivelor...	0101010101	1	1	1
D2	Prezenta o strategie implicită de aplicare a puterii moi în scopul realizării obiectivelor...	0101010102	1	1	1
D3	Prezenta o strategie de aplicare a puterii moi în scopul realizării obiectivelor...	0101010103	1	1	1
D4	Prezenta o strategie de aplicare a puterii moi în scopul realizării obiectivelor...	0101010104	1	1	1
D5	Prezenta o strategie de aplicare a puterii moi în scopul realizării obiectivelor...	0101010105	1	1	1
D6	Prezenta o strategie de aplicare a puterii moi în scopul realizării obiectivelor...	0101010106	1	1	1
D7	Prezenta o strategie de aplicare a puterii moi în scopul realizării obiectivelor...	0101010107	1	1	1
D8	Prezenta o strategie de aplicare a puterii moi în scopul realizării obiectivelor...	0101010108	1	1	1
D9	Prezenta o strategie de aplicare a puterii moi în scopul realizării obiectivelor...	0101010109	1	1	1
D10	Prezenta o strategie de aplicare a puterii moi în scopul realizării obiectivelor...	0101010110	1	1	1

După cum se poate observa, în urma corelării datelor cu cele trei ipoteze enunțate, softul ACII a generat cel mai mic nivel de inconsistență (1.414) celui de-al doilea enunț.

Acest aspect denotă faptul că aplicarea analizei ipotezelor concurente a condus la concluzia Federația (tutși este posibilă să utilizeze un *Soft Power* limitat (doar în anumite zone, preponderent în statele membre CSI).

*Annex 1 – Analysis of Competing Hypotheses  
Applying a scientific technique in order to ensure the objectivity of the conclusion, the soft generated the idea that the Russian Federation is capable of using a limited soft power.*

### 3.2. THE POWER OF THE BEAR

Since the non-violent side of the Russian power was presented in the previous chapter, the present one focuses on our state’s capacity of using the military means in a manner in which assures the Federation of achieving its objectives inside the dynamics today’s world.

Even though numerous voices today say that the military field lost its meaning and was taken over by the economic aspects, the truth is that it doesn’t, it maintained its coherence along the times and, together with the development of the states, industry and technology, it gained a more and more indispensable character. Inside today’s security environment, no state can exist and act without an army that is able to guarantee at least its territorial integrity.

Looking towards the Russian Federation, we must point out the fact that the top army of the Cold War was not available after the end of the Soviet Union and, because of the economic situation that followed, Russian Federation’s army couldn’t keep up with the development that other armies benefited from – such as the US army. Thus, the analysis concentrates on the two manners in which the hard power was used and is used by Russians.

First of all, in order to understand that even though Russians don’t have the top army, they are able to use the existing one properly, we can look at the last manifestation of this power. It is represented by the Russian military invasion of Georgia in 2008, where the Russian Federation demonstrated that it could produce the collapse of the enemy’s army by destroying their morale, exploiting their poor quality of communication systems and the lack of a top anti-missile system (Astrov, 2011:82). By this action, Russians managed to gain control over certain areas in Georgia that enable them to secure the transportation routes for natural gas they export. It is obvious how the Russian Federation achieved its economic and geopolitical goals by using hard power in this specific situation.





"HENRI COANDA" AIR FORCE ACADEMY  
FACULTY OF AERONAUTICAL MANAGEMENT  
ROMANIA

STUDENTS' INTERNATIONAL CONFERENCE AFASTUD 2015

Communicating Across Cultures

Brasov, 2<sup>nd</sup>-4<sup>th</sup> April 2015



"GENERAL M.R. STEFANIK"  
ARMED FORCES ACADEMY LIPTOVSKY MIKULAS  
SLOVAK REPUBLIC

Even though the intervention in Georgia is a clear manifestation of this kind of power, the hard dimension can also be seen through the presence of Russian Forces inside the former Soviet republics after the collapse of the Soviet Union – Russian Federation has military bases in Armenia, the Black Sea Fleet in Ukraine and in other areas from which it guarantees it has the capacity of intervening if their interests are in jeopardy.

But the concept of hard power manifested also through the creation, after the fall of USSR, of a number of infrastructures and dependencies in the energetic field between the former Soviet states and itself, used after 2000 for promoting national interests in other states. The use of price as a coercive technique can be observed in the case of Ukraine – when president was Leonid Kuchma, the Russian Federation sold gas to Ukraine at the price of 50 dollars per 1000 cubic meters, but after the Orange Revolution conducted by pro-Western forces, the price went up to 240 dollars per 1000 cubic meters (Astrov, 2011:84). Moreover, when the parties didn't reach a common conclusion, Russian Federation cut down on the gas exports to Ukraine (January 2006). Thus, it is clear that even though there doesn't exist a military presence, the fact that certain states depend on Russian resources for their survival determines Russian decision makers to use the energy as a tool for promoting their interests and determining those states to act according to them.

Taking into consideration the aspects presented above, we can conclude that the Russian Federation possesses, at this point, the necessary capabilities in order to benefit from the use of hard power. Its military capacity and presence and its status of sole exporter of energy enables the Bear to maintain the power of achieving its goals on an international scale.

*Annex 2 – Analysis of Competing Hypotheses  
Applying a scientific technique in order to ensure the objectivity of the conclusion, the soft generated the idea that the Russian Federation is capable of using a fully functioning hard power.*

H	Credibility/Potential	Hypotheses		
		H 1	H 2	H 3
		Federatia Rusă nu dispune de HARD POWER	Federatia Rusă dispune de HARD POWER numai în anumite regiuni	Federatia Rusă dispune de HARD POWER competitiv la nivel mondial
	Weighted Inconsistency Score (0)	-0.242	-0.028	+4.0
	Order Evidence			
E6	HIGH	MEDIUM	I	C
E6	HIGH	HIGH	I	C
E7	HIGH	HIGH	I	C
E8	MEDIUM	MEDIUM	C	C
E5	HIGH	MEDIUM	I	C
E4	HIGH	LOW	C	I
E2	MEDIUM	MEDIUM	C	I
E3	MEDIUM	MEDIUM	C	C
E1	MEDIUM	MEDIUM	I	C

După cum se poate observa în urma corelării dovezilor cu cele trei ipoteze enunțate, softul ACH a generat cel mai mic nivel de inconsistență (-4.0) celui de-al treilea enunț.

Acest aspect denotă faptul că aplicarea instrumentului de obiectivizare „analiza ipotezelor concurente” a condus la concluzia că Federația Rusă dispune de HARD POWER competitiv pe scena relațiilor internaționale a secolului XXI.

3.3. A SMART BEAR?

This chapter intends to determine whether the Russian Federation is capable of integrating military and non-military means in order to gain a competitive position among the important actors on today's global scene.

First of all, Russia is today the biggest natural gas producer in the world and, as was presented above, by knowing this status, it uses it as the main instrument for promoting the foreign policy in some areas. Moreover, because it realized the necessity of thinking globally, it doesn't anymore think of itself as the only relevant actor in the energy field and focuses on keeping the power among the 'lions': activates in G8, BRICS and Troika (Russian, India, China).

Secondly, beside this energetic dimension of hard power, it can be observed that the military field, even though technologically less advanced in comparison with the West, is still capable of securing the territory and fulfill incursions like the one in Georgia. Moreover, the status of a stat with nuclear bomb represents another element that positions the Russian Federation in the area of a relevant hard power.

But, taking into consideration the fact that military intervention in other state's territories is not at all times legitimate, the achievement of strategic objectives must be corroborated

with soft power actions in order to gain coherence.

On the other hand, referring to the second type of power, the analysis doesn't concentrate on the confirmation that Russia is capable of using it, but on the degree in which it can project soft power in all the interest zones. Using the example of Crimea, we can see how the soft dimension was prepared in an organized manner, benefiting from the support and coordination of the Kremlin. But in Crimea, Belarus or Moldavian Republic, the Russian rhetoric is interiorized and functions because of the fact that these peoples lived under the influence of a Russian way of thinking, of their values and ideology. Thus, this rhetoric cannot be used and has no impact over the individuals who live in states that didn't situate themselves on the Eastern side of the Iron Curtain. Elements such as passport policy, the use of Orthodox Church or the NGOs won't have an echo in other areas such as the Western hemisphere.

In addition, what Vladimir Putin tries to achieve through media can be considered a certain manifestation of soft power, taking into consideration the fact that he wants to use it in order to foster the cohesion and patriotic feelings inside Russian population all over the world and also to counter the creation of a bad image for the Russian Federation – the one of an aggressor and non-legitimate actor – building a more beneficial one – a player who is capable of occupying the same position of other global powers.

All in all, taking into consideration the degree in which the Russian Federation has the necessary potential of the two powers in order to achieve its objectives and the manner in which the decision makers use this potential, we can conclude that this state started to make its way towards using smart power since Vladimir Putin's reforms, but didn't manage to get it to a level capable of offering the power and position of one of the major players at global scale.

#### 4. CONCLUSION

To sum up, the paper achieves its main objective of analyzing one of the major aspects

in the international relations field of today – the manifestation of the Russian Federation and its impact on the collective psychic. The international environment generated the necessity of reconfiguring actors' behavior and they have now not only to take into consideration the use of violent means or non-violent ones alone, but the integration of those two types of elements, in order to generate a smart power that functions unitarily.

In this context, taking into account Russian Federation's intention to become an actor with global interests and influence, the present paper tried to point out its capacity of interiorizing the type of power above-mentioned, concluding that it clearly started to have this capacity, but not one of a global competitiveness. The purpose of conducting this analysis, also through the Analysis of Competing Hypotheses, is that of pointing out the present power of Russian Federation and the future ability of projecting its interests at a global scale and influence the Balance of Power all over the world.

*The Big Russian Bear is today smart, but has to learn a little bit more to become one of the 'kings of the jungle'*

#### BIBLIOGRAPHY

1. DOYLE, Michael, [1986], *Liberalism and World Politics*
2. GRIFFITHS, Martin, [2003], *Relații internaționale: coli, curente, gânditori*
3. MORGENTHAU, Hans, [1946], *Scientific Man versus Power Politics*
4. NYE, Joseph, [2004], *Power in the Global Information Age: From Realism to Globalization*
5. NYE, Joseph, [2004], *Soft Power: The Means to Success in World Politics*
6. NYE, Joseph, [2008], *Smart Power in Iran-U.S. Relations*

#### Online sources:

1. ASTROV, Alexander, [2011] *Great power (mis)Management: The Russian-Georgian War and Its Implications for the Global*



- Political Order*, available at <http://books.google.ro/books?id=rHrn0B5-or0C&printsec=frontcover#v=onepage&q&f=false>, accessed on 27<sup>th</sup> December 2014, 13:45
2. EITELHUBER, Norbert, [2009], *The Russian Bear: Russian Strategic Culture and what it implies for the West*, available at <http://procon.bg/article/russian-bear-russian-strategic-culture-and-what-it-implieswest>, accessed on 27<sup>th</sup> January 2015, 18:08
  3. ERMARTH, Fritz, [2006], *Russia Strategic culture*, available at <http://www.fas.org/irp/agency/dod/dtra/russia.pdf>, accessed on 28 January 2015, 10:22
  4. GURBANOV, Ilgar, [2013], *Energy in Russian foreign policy: Soft Power, Hard Power or Smart Power?*, available at <http://www.strategicoutlook.org/asia---pasific/news-energy-in-russian-foreign-policy--soft-power-hard-power-or-smart-power.html>, accessed on 12<sup>th</sup> February 2015, 15:50
  5. GVOSDEV, Nikolas, [2011], *Because It Is: Russia, The Existential Great Power, The National Interest*; available at [https://www.gwu.edu/~sigur/assets/docs/major\\_powers\\_091407/Gvosdev\\_on\\_%20Russia.pdf](https://www.gwu.edu/~sigur/assets/docs/major_powers_091407/Gvosdev_on_%20Russia.pdf) accessed on 2<sup>nd</sup> February 2015, 13:20
  6. IVER, Neumann, [2007], *When did Russia become a great power?*, available at [http://citation.allacademic.com/meta/p\\_mla\\_apa\\_research\\_citation/1/7/9/6/7/p179679\\_index.html?phpsessid=v613t021lbdn3rm6g3chmb837](http://citation.allacademic.com/meta/p_mla_apa_research_citation/1/7/9/6/7/p179679_index.html?phpsessid=v613t021lbdn3rm6g3chmb837), accessed on 13<sup>th</sup> February 2015, 11:55
  7. ROSLYCKY, Lada, [2011], *Russia's smart power in Crimeea: sowing the seeds of trust*, 2011, <http://www.tandfonline.com/doi/full/10.1080/14683857.2011.590313#.VJ6-If8BA>, accessed on 4<sup>th</sup> February 2015, 16:07





## SIMULATION OF SIMPLEX RADIO COMMUNICATION IN LAN NETWORKS

**Marek Lipták**

Department of Electronics  
Armed Forces Academy of General Milan Rastislav Štefánik  
Liptovský Mikuláš, Slovak Republic

**Abstract:** *The paper presents a software tool for simulation of simplex radio communication in LAN network. The aim of the simulator is to provide tool for training radio communication procedures, which can be used in the classroom without radiation of electromagnetic power and without using of radios. Proposed simulator is also suitable for simulation of radio communication in simulation center for training of command and control procedures, where radios cannot be used.*

**Keywords:** *training of radio operators, multicast for voice broadcasting, TCP, UDP, IP.*

### 1. INTRODUCTION

Radio communication is the main mean of communication for command and control of tactical units in nowadays battlefield. Simplex operation in tactical radio networks is mostly used for voice communication. To establish proper and reliable radio communication, radio operators, soldiers and staff have to be trained to use proper communication procedures in radio networks.

Although training with real radios is the best way how to learn radio communication procedures, at the very beginning of training it is better to put all students together into one classroom, to explain them radio communication procedures, to train them in classroom and after that train radio communication with radios on real distances.

To enable training without radiation of electromagnetic energy it is needed to use some tools for simulation of simplex radio communication.

Such a tool is also suitable for simulation of radio in simulation centers for training of

command and control procedures, where using of radios is unwanted.

### 2. PROTOCOLS IN LAN NETWORKS

The Internet protocol suite uses encapsulation to provide abstraction of protocols and services. Encapsulation is usually aligned with the division of the protocol suite into layers of general functionality. In general, an application (the highest level of the model) uses a set of protocols to send its data down the layers, being further encapsulated at each level.

Viewing layers as providing or consuming a service is a method of abstraction to isolate upper layer protocols from the details of transmitting bits over, for example, Ethernet and collision detection, while the lower layers

avoid having to know the details of each and every application and its protocol.

RFC 1122 [1], is structured in paragraphs referring to layers, but the document refers to many other architectural principles not emphasizing layering. It loosely defines a four-layer model, with the layers having names, not numbers, as follows:

**The Application Layer** is the scope within which applications create user data and communicate this data to other applications on another or the same host. The applications, or processes, make use of the services provided by the underlying, lower layers. The communications partners are characterized by the application architecture, such as the client-server model and peer-to-peer networking. Processes are addressed via ports which essentially represent services.

**The Transport Layer** performs host-to-host communications on either the same or different hosts and on either the local network or remote networks separated by routers. It provides a channel for the communication needs of applications. **UDP** (User Datagram Protocol) is the basic transport layer protocol, providing an unreliable datagram service. **TCP** (Transmission Control Protocol) provides flow-control, connection establishment, and reliable transmission of data.

**The Internet Layer** has the task of exchanging datagrams across network boundaries. It provides a uniform networking interface that hides the actual topology (layout) of the underlying network connections. This layer defines the addressing and routing structures used for the TCP/IP protocol suite. The primary protocol in this scope is the Internet Protocol, which defines IP addresses. Its function in routing is to transport datagrams to the next IP router that has the connectivity to a network closer to the final data destination.

**The Link Layer** defines the networking methods within the scope of the local network link on which hosts communicate without intervening routers. This layer includes the protocols used to describe the local network topology and the interfaces needed to effect transmission of Internet layer datagrams to next-neighbor hosts.

Communication in network can be classified according to the destination as follows (see. Figure 1):

- **unicast** transmission is the sending of messages to a single network destination identified by a unique address (see Figure 1 a),
- **multicast** (one-to-many or many-to-many distribution) is group communication where information is addressed to a group of destination computers simultaneously (see Figure 1 b),
- **broadcast** refers to a method of transferring a message to all recipients in subnet simultaneously (see Figure 1 c).

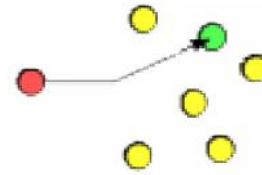

a. unicast

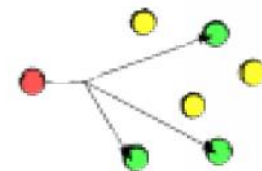

b. multicast

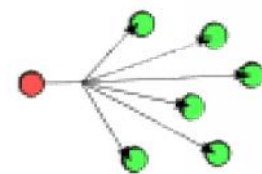

c. broadcast

Fig. 1: Classification of communication in network according to the destination

### 3. MULTICAST

Network assisted multicast may be implemented at the Internet layer using IP multicast, which is often employed in Internet Protocol (IP) applications of streaming media,



such as Internet television scheduled content and multipoint videoconferencing. In IP multicast the implementation of the multicast concept occurs at the IP routing level, where routers create optimal distribution paths for datagrams sent to a multicast destination address.

Network assisted multicast may also be implemented at the Data Link Layer using one-to-many addressing and switching such as Ethernet multicast addressing.

The most common transport layer protocol to use multicast addressing is User Datagram Protocol (UDP). By its nature, UDP is not reliable—messages may be lost or delivered out of order. By adding loss detection and retransmission mechanisms, reliable multicast has been implemented on top of UDP or IP by various middleware products. [2]

The range of IP addresses is divided into "classes" based on the high order bits of a 32 bits IP address. The one which concerns us is the "Class D Address" 224.0.0.0 - 239.255.255.255. Every IP datagram whose destination address starts with "1110" is an IP Multicast datagram. The remaining 28 bits identify the multicast "group" the datagram is sent to. Following with the previous analogy, you have to tune your radio to hear a program that is transmitted at some specific frequency, in the same way you have to "tune" your kernel to receive packets sent to an specific multicast group. [2]

The range 224.0.0.0 through 224.0.0.255 is reserved for local purposes (as administrative and maintenance tasks) and datagrams destined to them are never forwarded by multicast routers. [2]

In principle, an application just needs to open a UDP socket and fill with a class D multicast address the destination address where it wants to send data to. However, there are some operations that a sending process must be able to control.

**The TTL (Time To Live)** field in the IP header has a double significance in multicast. As always, it controls the live time of the

datagram to avoid it being looped forever due to routing errors. Routers decrement the TTL of every datagram as it traverses from one network to another and when its value reaches 0 the packet is dropped. The TTL in IPv4 multicasting has also the meaning of "threshold". Setting TTL to 1 will ensure that multicast packet will never leave your subnet. [2]

When the sending host is also a member of the group datagrams are being sent to, a copy is **looped back** by default. This feature is desirable in some cases, but not in others. So the sending process can turn it on and off at wish. [2]

#### 4. REQUIREMENTS FOR SIMULATOR OF SIMPLEX RADIO COMMUNICATION

The basic requirement is to provide full control over simulation process. Therefore, simulator should be realized in client – server architecture. Form this point of view, the requirements for simulator can be divided into the requirements for the server application and the requirements to the client application.

##### 4.1 Requirements for the server application

The server application should fulfill the following functions:

- to register all running client applications when connected,
- after client application is connected, to provide configuration of radio networks to client application,
- after client application is connected, to provide configuration of noise level in radio channel to client application,
- to monitor participation in radio networks (in which radio network clients operates),
- to listen communication in selected radio network,

- to record communication in selected radio networks,

#### 4.2 Requirements for the client application

The client application should fulfill the following functions:

- to connect to server application when started,
- to receive configuration of radio networks from server,
- to receive configuration of noise level in radio channel from server,
- to apply noise distortion to all received traffic,
- to simulate radio front panel
  - to simulate radio display and show on it the information about selected radio network,
  - to simulate radio keypad to enable selection of radio network,
  - to simulate PTT (Push To Talk) button (radio is transmitting when PPT is pressed)
- to send voice from microphone to multicast address configured for radio network when PTT button is pressed,
- to send received and by noise destroyed multicast traffic to headphones when PTT is not pressed,
- to send notification about change of radio network to server application.

### 5. SIMULATOR IMPLEMENTATION

Simulator was programmed in Object Pascal in Dephi 7 programming environment.

Simulator enables to configure 9 radio networks at server application user interface. Each radio network is simulated as one multicast group in LAN subnet. TTL is set to 1 to disable routing of multicast outside the subnet. The following parameters can be configured for each radio network (see Figure 2):

- the name (up to 20 letters),
- the frequency,
- the multicast IP address,

- port of multicast (must be same for all multicast addresses).

Communication between client and server was programmed as TCP socket. Communication protocol over TCP socket was designed to fulfill requirements. The following messages were designed and implemented:

**GetConfig()** – request for configuration of radio networks. The message is sent from client to server after TCP connection is established.

**Config()** –configuration of radio network. The message is sent from server to client for each radio network as response to message GetConfig() .

**AckConfig()** – acknowledgement of Config() message. The message is sent from client to server as response to message Config() .

**NetChange()** – information about change of network. The message is sent from client to server when user changes network.

**Ack NetChange()** – acknowledgement of NetChange() message. The message is sent from server to client as response to message NetChange() .

**SetNoise()** –configuration of noise distortion. The message is sent from server to client to set noise distortion level.

**AckSetNoise ()** – acknowledgement of SetNoise() message. The message is sent from client to server as response to message SetNoise() .

	Název	Frekvencia	Adresa
KANAL1	Net1	30,000	224.0.1.10
KANAL2	Net2	31,000	224.0.2.10
KANAL3	Net3	32,000	224.0.3.10
KANAL4	Net4	41,000	224.0.4.10
KANAL5	Net5	45,000	224.0.5.10
KANAL6	Net6	68,000	224.0.6.10
KANAL7	Net7	48,000	224.0.7.10
KANAL8	Net8	39,000	224.0.8.10
KANAL9	Net9	51,000	224.0.9.10

Port je pre všetkých rovnaký: 33000 [Cancel] [OK]

Fig. 2: User interface for configuration of radio networks





Server application user interface is shown on Figure 3. Client list is on the left side. When client connects the first time it is represented in list as "unknown client" (last client in the list) connected to the server. The name of "unknown client" is its IP address. To all client at server side the name of client can be assigned. Such clients are called as "known client" and the name assigned to IP address is shown in list. All known clients defined on server are shown in list. If the known client is connected its color is green, red is used for unconnected clients. Unknown clients are shown in list only when they are connected to server.

When client is selected in the list, all information about client is shown on right side (remote address, host name, time of last connection, actual network in use, known/unknown info).

At the bottom of window information about communication in TCP socket is shown to enable monitoring of TCP communication.

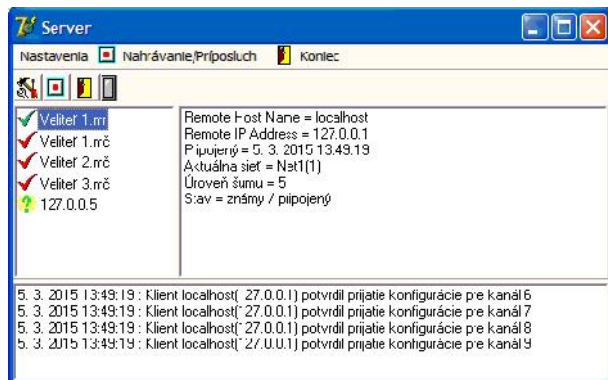

Fig. 3: Server application user interface

Server application allows recording and listening-in. User interface for configuration of recording/listening-in is shown on Figure 4. There is a possibility to select recording for all radio networks. All records are saved in selected destination folder. Name of recorded file is generated automatically and it consists from network name, date and time. Recorded

files can be played back when required. Only one radio network can be selected for listening-in.

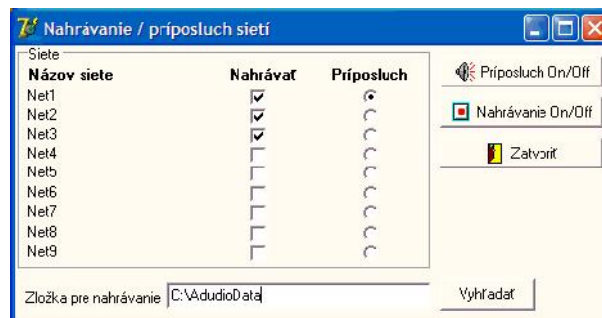

Fig. 4: User interface for configuration of recording/listening-in

Client application user interface is shown on Figure 5. Information about selected radio network, name and frequency are displayed on the display in upper part. The left side of display indication of receiving/transmission is shown by letters R and T. One of nine radio networks can be selected by click on the buttons. Push to talk (PTT) button is used to switch between the functions, transmitting when pressed, receiving when released.

The LED in left top corner signalizes status of TCP connection to server. When the client application is connected to the server LED is green, otherwise it is red. When running the client application the first time and the preconfigured server address is unreachable, the dialog window pops up to enable setting of the server IP address and port for TCP socket between client and server. Because all configurations of clients are done from server through TCP socket, simulator cannot run while the server application is not running.

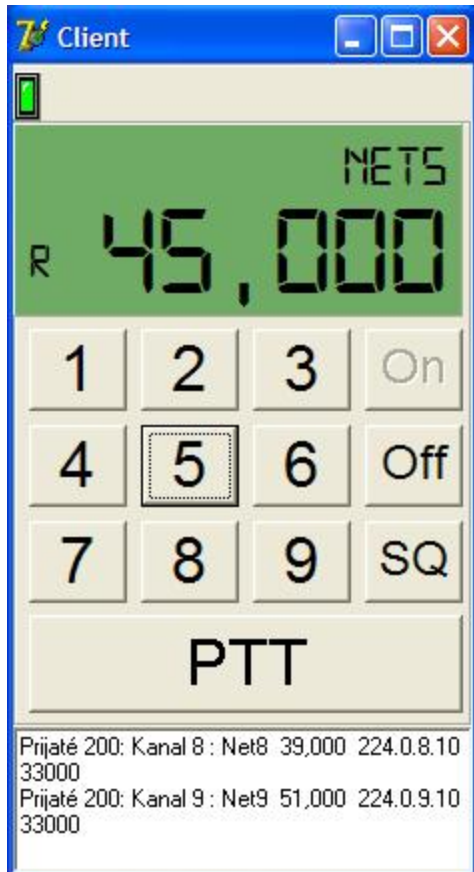

Fig. 5: Client application user interface

When application is in receiving mode (PTT button is released, R is shown on the left side of display), the multicast server socket is deactivated, the multicast client socket is active in multicast group configured for the selected radio network. Multicast client socket receives voice packets sent by one of multicast servers (if any of servers is active), adds additive noise to the received voice samples according to the noise level set from server and sends distorted samples to headphones.

When application is in transmitting mode (PTT button is pressed, T is shown on the left

side of display), the multicast client socket is deactivated, the multicast server socket is active in multicast group configured for the selected radio network. Voice samples from microphone are captured, segmented and sent via UDP to the multicast group. The sent packets are received by active clients in multicast group.

At the bottom of client application information about communication in TCP socket is shown to enable monitoring of TCP communication.

## 6. CONCLUSION

This paper presents simulation of simplex radio communication in LAN networks. Simulator enables configuration of 9 radio networks with unlimited number of radios inside each network. Simplex communication in each radio networks is simulated as transmission and reception of voice packets in multicast group.

Simulator can be used for the communication procedures training of radio operators. It can be also used at simulation center to simulate radio communication in command and control procedures training of staff where using of radios is impossible.

## BIBLIOGRAPHY

1. RFC1122, Requirements for Internet Hosts - Communication Layers, Internet Engineering Task Force, 1989.
2. J. -M. de Goyeneche: Multicast over TCP/IP HOWTO, <http://www.tldp.org/HOWTO/Multicast-HOWTO.html>



## THE EFFECTS OF ASHKENAZI ETHIC SEGREGATION ON THE DEVELOPMENT OF YIDDISH. SPECIFIC PATTERNS IN VOCABULARY

Ilie Iulian MITRAN \*\* Mihaela RUS \*\*\* Mihaela SANDU

Ovidius University of Constantina

**Abstract:** *Yiddish, for those who are part of the traditionalist faction of language scholars from German-speaking Europe was a subject that should be avoided at all costs, being labeled as a bastard language that holds no legitimacy within the upper class society. From a different perspective, Yiddish is the perfect example of a language's downfall as a result of its total exclusion from institutional life.*

*This paper aims at analyzing the effects that institutional exclusion and ethnic segregation had on the language's development, the focus will be on proving if or if not the two aspects that were mentioned earlier had any relevant influence on the development of the language's vocabulary.*

*The comparative analysis of languages that never received an official status, or of those that had it for a insignificant time span or that was present only at a local/regional level, can result with the identification of some common development trends and similarities in regards to a language's vocabulary inconsistencies in certain fields . This paper will expose a number of theoretical aspects in regards to Yiddish's vocabulary structure but it will be mainly based on an interview which will aim at answering to the following question: Did ethnic segregation influence or not the development of the Yiddish vocabulary?.*

**Keywords:** *segregation, exclusion, Yiddishism, patterns, linguistic development, standardization*

<sup>1</sup>Jiddisch, <sup>2</sup>Yiddish, or "German Jewish" (derogative term), or the name of a story of abuse, acculturation and rebirth. The history of Yiddish is vast and it is identifiable with a very well outlined both oral and written tradition, making it a good candidate for the title of *European language of culture*, even thou this would had never been acknowledged at a continental level do to the stigma which always haunted the social relations between

the Central and Eastern European Jewry (Ashkenazi) and the <sup>3</sup>gentiles. Stigma had manifested in various forms, from the most obvious to the most perverted and subliminal, in the end, the consequence was very clear, the exclusion of Jews and their language from the social life of the communities in which they dwelled.

<sup>1</sup> The German word for Yiddish.

<sup>2</sup> Derived from "id" – the German word for Jew.

<sup>3</sup> Non-Jews.

As a result, *Yiddish*, and <sup>4</sup>*Yiddishism* along with it, received the label as unworthy, dirty and unauthentic, a language used by the misfits of that time, the Jews. The segregation of the *Jewish language* was present both on a micro and at a macro level, from the narrow streets and markets of the most common towns to the level of the state's local and central administrative institutions. The institutional exclusion that Yiddish had a considerable contribution to many of the language's developmental delays, most noticeable, the hardships that it faced in the attempt to form a standard writing system that would be accepted by both the communities from the western and from the eastern regions of the continent.

This paper intends to analyze, from the perspective of linguistic anthropology, the specific patterns that are found in languages that were historically deprived of any form of an official recognition, furthermore it will highlight the development delays present in Yiddish's development patterns that are directly sourced to its <sup>5</sup>*institutional exclusion*.

"Patternology" represents that interest in analyzing developmental patterns, a pattern represents a developmental trajectory that has a high frequency in a specific context.

The standardization of Yiddish writing was one of the biggest obstacles that the modern language had to face, the hardships primarily resulted from an incapacity of the Jews to neutralize the pressure that came from the majority which dictated at one point the preference towards a certain writing system.

The correlation between language and the socio-economic development level that a group has represents a point of interest for linguistic scholars nowadays. Yiddish contains a number of interesting characteristic that are not present or not as well outlined in other languages, those being:

1. *Chamber structure* – the language's vocabulary is "split" in to three sections, the divisions is made by using as criteria the origin of the words, as a result, the Yiddish vocabulary can be represented as :  $Y_{Germanic} + Y_{Hebrew-Aramaic} + Y_{Slavic}$ . This division has an actual function in regards to the language's grammar, it rather servers as a way of forming a hierarchy between words by the criteria of their origin, this way, *Hebrew and Aramaic words* are considered "holier" then the words from German and the Slavic languages, even thou they comprise a minority.

*Can be this internal division of words by their origin be considered a byproduct of ethnic segregation?*

2. *The Holy Chamber*- If we compared the internal division of the Yiddish vocabulary with the image of *three chambers*, we can state that *Loshn-Koidesh* is the chamber that holds a privileged status, being the chamber that retains the majority of words that make references to aspect of the traditional Ashkenazi forms of religiosity and way of life.

3. *Differences in regards to the phonetic or traditional writing of Losh-Koidesh words*– Differences that were mainly dictated by various interests that the political power had towards the Ashkenazi community, having the purpose of slowly diluting the most distinctive and holy component that the language has. Traditionally, *Loshn-Koidesh* words were never written using a phonetic writing system, they were written according to the rules used by the *Semitic Writing System* (Hebrew, Aramaic, Arabic etc) which is characterized exclusion of vowels from writing, the presence of vowels is indicated by using indicators that take the form of dots and lines in Hebrew. The following table gives some examples of *Loshn-Koidesh words* written both in the traditional and the phonetic system:

<sup>4</sup> Term that makes reference to an interest and a preference towards using Yiddish as a language in both the family environment and in various field (art, literature, poetry etc) rather than the language of the outsiders.

<sup>5</sup> In this study it is used to describe languages that were historically deprived of any form of official recognition.



Traditional system	Traditional system (Latin Script)	Phonetic system (Hebrew Scrip)	Translation
שבת	<i>shbh</i>	שאַבעס	Sabbath
משפחה	<i>mshgkhh</i>	מישפּאַכע	family
פנים	<i>pnim</i>	פּאַנים	face
רחל	<i>Rkhl</i>	ראַכעל	Rakhel (Jewish name)

Figure 1 – Example of Losh Koidesh words written with both the phonetic and traditional system

4. *A low degree of diglossia* – This aspect can be a good indicator of a language's homogeneity, in the same time, it can indicate the impact that a language's social status had on the development of its vocabulary. Usually, languages that were associated with segregated groups have a low degree of *diglossia* as a result of a group's lack of penetration in certain socio-economic fields, this way, no specialized vocabulary came in to being, thus the degree of polarization between the literary language and the "language of daily talk" is quite insignificant. In the case of Yiddish, the low degree of *diglossia* doesn't come from a lack of socio-economic development of the Ashkenazi, it is rather sourced to an exterior pressure that determined a preference towards keeping the language as homogeneous as possible in order to harden any attempt that aimed at assimilating the language.

This interest for keeping a certain degree of homogeneity within the language's vocabulary translated at one point in history in to a unique concept, that of a land of the Yiddish language that peacefully coexisted with all of the states in which its supposed territories were assimilated.

*Yiddishland*, a "nation" that peacefully existed within other nations is an enigma for Europeans nowadays, it consisted of territories that are part of Poland, Lithuania, Ukraine, Belarus, Moldova and Romania. As some would be tempted to think, *Yiddishland* was never a state formation, nor a historic region, nor a territorial administrative division of any kind.

It was just the name that was give by the <sup>6</sup>Ashkenazi Jewry to the territories of Eastern Europe in which Yiddish had a considerable number of speakers. *Yiddishland* is that "nation" that was lost without existing in the first place, the term was primarily known only by Jews, the gentiles disregarding any type of historical legitimacy that term would have.

An interesting characteristic of *Yiddishland* is that it represents an attempt of creating a sense of unity between Yiddish speakers through outlining a "phantom state" which will be a bastion of *Yiddishism*. It must be mentioned that *Yiddishland* never represented in any shape or form the a point in the agenda of setting a clear ground for the creation of an Ashkenazi national state, nor it was setting the ground for an autonomous region/province in any of the Eastern European States with a significant number of Yiddish speakers. The idea that stood behind *Yiddishland* was that of a symbolic representation of the linguistic unity of the Ashkenazi through the existence of a land that traces its borders according to the distribution of the Yiddish within Eastern Europe. As a consequence, *Yiddishland* didn't base its existence on ideas that related to nationalism or separatism.

Each dialect has a number of particularities, ranging from vocabulary and phonetics to the writing system, it should be mentioned that each dialect has its own set of forms of cultural expression, the coming in to being of such forms of cultural expression was mainly

<sup>6</sup> The Jews that lived in the German-speaking territories of Central Europe and in parts of Eastern Europe.

dictated by the interference of regional influences, or better said, the influence of the ethnic majority on the minority.

In order to see the general perception on the language's weak and strong points in regards to its <sup>7</sup>*specialized vocabulary* from certain fields, a semi-structured interview was applied. The data collected from it will aim at shedding some light on how well Yiddish managed to form a *specialized vocabulary* in certain domains, the social factors had contributed and the domains in which the *specialized vocabulary* is mainly formed from borrowings from other languages.

The correlations between social trends and language development will represent a special interest in this paper as a result of that fact that cultural norms come to be acknowledge through the use of language, taking this in to consideration, the language must adapt to certain communicational contexts, thus the usage of a certain selection of words and of the right <sup>8</sup>*speech template* becomes mandatory.

### **Social imagery and vocabulary**

#### **Comparative perspective: Rromani**

**Hypothesis:** *Rromani and Yiddish developed quite similarly as a result of the impact of ethnic segregation.*

#### **Acknowledgements**

A comparative study between the development of Yiddish and Rromani in correlation with to the role played by social-economic factors can have as a result the discovery of common patterns of development. The result are the product of the processing of data that was collected from an interview applied to two native Rromani-speakers and one non-native speaker, the first participant, Doru Dima (male, age 44), is a Ph.D. student at the Doctoral School of Sociology, the second participant, Sorin Georgescu (male, age 45), is a authorized translator, graduate of the Faculty of Letters from the University of Bucharest.

---

<sup>7</sup> Words that define concepts and notions assimilated to a certain field of study.

<sup>8</sup> Structure of a speech and preference towards the usage of a certain selection of words, expressions and voice tonalities.

**Question 1** – Do you think that Rromani relies on borrowings from other languages in certain fields (medicine, culture, science etc)?

**Doru:** *Rromani doesn't rely on borrowings from other languages in certain domains more than many other languages from Europe.*

**Sorin:** *I think that rather the speakers and experts from certain domains are more tempted to use borrowings in certain contexts, not the language itself. Rromani, as any other language, has the possibility of creating specialized vocabularies both relying on internal or external word formations. Rromani contains both words borrowed that define concepts that are not traditionally associated to the Rroma way of life (demokracìa, standardizàcia, revolùcia, matemàtika, kompensàcia, pràktika, xaraktèro etc) but it also contains internally formed words that define concepts that don't have a direct translation in other languages, like: navni= noun (derived from anav" name"), pašnavni=adjective( lit. „next to the name”), kernvani=verb (lit. „name that does something”), paškernavni=adverb (lit. „next to the name that does something”).*

**Question 2** - What effect did the ethnic segregation of the Rroma had on the development of Rromani?

**Doru:** *Ethnic segregation had a huge impact on the development of Rromani, a very well know case is that of the Rudari, Rroma group that stopped speaking the language as a way of escaping social persecution, the language being associated with the low classes of the Romanian society of that time and it still is up to the present.*

**Sorin:** Rromani contains words that describe a type of “we and the ones that are different from us” type of vision of society, even so, this is usually a characteristic associated with patriarchal societies. The Japanese have the word *gaijin* (person from somewhere else), in Rromani we have the words: *ga o*, *ga i* = non-Rroma man, woman ; *havo*, *hej* = Rroma boy and girl; *raklo*, *rakli* = non-Rroma boy, girl.

**Research structure and methodologies** – *Was the development of the Yiddish influenced by the ethnic segregation of its speakers?*



**Hypothesis:** The development of Yiddish was greatly influenced by social-institutional segregation of the Ashkenazi.

**Acknowledgements**

This study is based on a series of interviews with a group formed from six language enthusiasts, two of them being a Yiddish-speakers, the other three being a non-speaker but that has a solid knowledge on the history and culture that surrounds that define the language. The interview aims at describing the perceptions that surround the correlation between ethnic segregation and language development putting a stress on vocabulary related aspects. The study intends to list some of the trends that formed in regards to the social influences that shaped the development of Yiddish. It should necessarily be taken in to consideration the fact that the results of the interview only have the purpose of listing a couple of the existing ideological trends in regards to the issues exposed in the previous lines, they don't exclude, nor do they represent a definitive answer in any way, shape or form.

1. Do you think that the ethnic segregation of the Ashkenazi had any effect on the development of Yiddish?

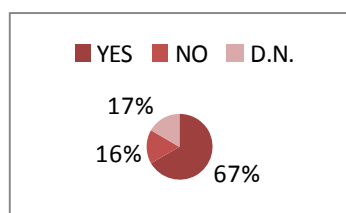

Figure 2 - Graphic representation of interview data

2. Name the fields in which Yiddish had to rely on borrowings (loanwords) from other languages:

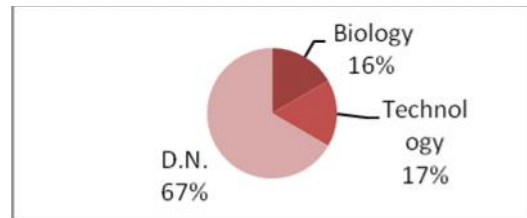

Figure 3 - Graphic representation of interview data

3. Do you think that the lack of an official status contributed to the apparition of differences in writing system and vocabulary?

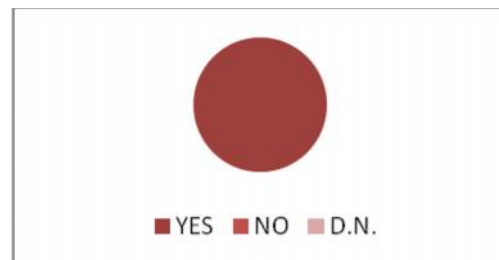

Figure 4 - Graphic representation of interview data

4. In which field Yiddish has the most well outlined specialized vocabulary (it is rich in terms that are not borrowed from other languages/ it uses its own terms which can't be understood by speakers of other languages)?

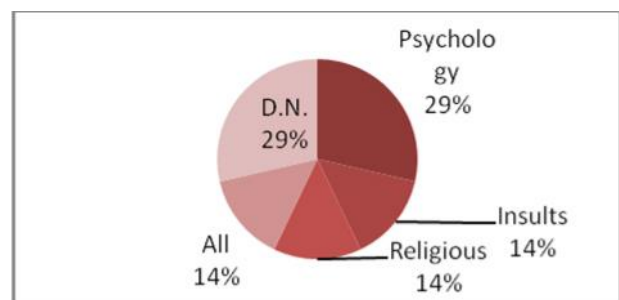

Figure 5 - Graphic representation of interview data

5. Can be Yiddish considered a *European Language of Culture*?

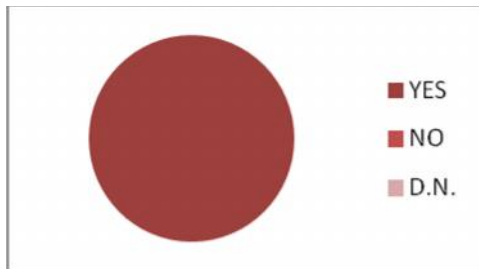

Figure 6 - Graphic representation of interview data

6. Write down 10 Yiddish words that are the most representative when talking about Ashkenazi culture (Latin scrip).

John: *shmuck, shlimeil, shlimazl, putz, mensh, balabusta, yenta, luftmensch, hokhem, and baal-tschuvah.*

Antonio: *Hamas, Hannukka, Habibi, Marhaba...Barmitzfah, Jeans, Abraham, Ham, Josef, Ibrahim ...Israel.*

Hans: *A sheynem Dank, Zayt gesunt.*

Jon: *shtetl, knish, glatt, pareve, shmuck, dreck, mishuganeh, mishpukah, shmaltz, bube.*

Jonathan: *dreidl, latles.*

Timo: Don't know.

7. Should *Loshn-Koidesh* words be written using the European writing system (that also includes the writing of vowels)?

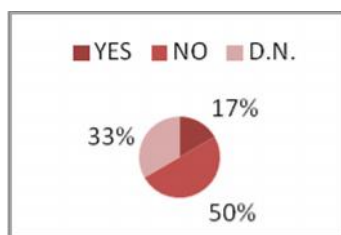

Figure 7 - Graphic representation of interview data

8. Which nation do you think that had the most violent policies directed towards Yiddish?

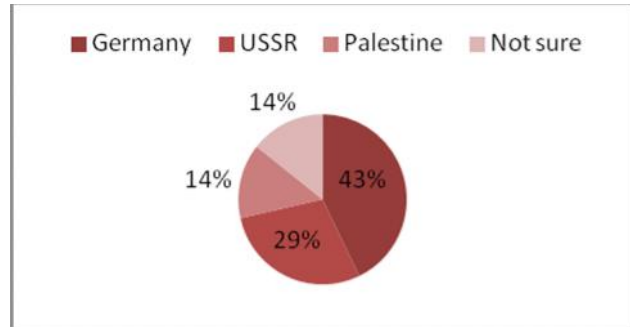

Figure 8 - Graphic representation of interview data

## CONCLUSIONS

1. Even if the majority of participants agreed on the fact that segregation had a direct effect on the language's development, it seems that it rather effected its capacity to develop a standard writing system. It was agreed that Yiddish doesn't suffer from a lack of specialized words in any specific field.

2. The majority of words that were used to describe Ashkenazi culture were connected to concept of the traditional Jewish home, traditional Jewish names, family, and to a lesser extent, the State of Israel. Historically, there's no real connection between Ashkenazi culture and Israel, many Ashkenazi seek shelter in Israel where their native language slowly started to fade. On the other hand, this association shows that the Ashkenazi are seen as an integral part of the worldwide Jewry.

3. Taking in to account only the data that we obtained from the interviews, it's hard to state the exact intensity that segregation had on the development of Rromani and Yiddish, one link between the two of them is the standardization process that was quite late and it was directly connected to the lack of an official status. Historically, Yiddish had an official status in the Ukrainian People's Republic (1917-1921), nowadays the only place where it is an official language is Jewish Autonomous Oblast from Russia.

4. The connection between this two languages are somewhat relative, segregation was harsher in the case of Rromani which for most of its history existed only in an oral form and its literature was developed quite late in comparison to Yiddish.





"HENRI COANDA" AIR FORCE ACADEMY  
FACULTY OF AERONAUTICAL MANAGEMENT  
ROMANIA

## STUDENTS' INTERNATIONAL CONFERENCE AFASTUD 2015

*Communicating Across Cultures*

Brasov, 2<sup>nd</sup>-4<sup>th</sup> April 2015



"GENERAL M.R. STEFANIK"  
ARMED FORCES ACADEMY LIPTOVSKY MIKULAS  
SLOVAK REPUBLIC

5. A distinctive feature of Yiddish is its *chamber system*, a delimitation between words in connection to their origins.

6. *Loshn-Koidesh words* are essential for the survival of the language, they are considered the bridge between the mundane and the holy, using the European system of spelling in their case is controversial and it is regarded as disrespectful.

7. Germany is perceived as the biggest aggressor, even thou, the USSR had some policies that aimed at the assimilation of the language.

## BIBLIOGRAPHY

1. Glinert, L. (1989), *The Grammar of Modern Hebrew*, London : Cambridge University Press
2. Katz, D. (1987), *The Grammar of the Yiddish Language*, London: Duckworth Publishing;
3. Khan, L. (2012), *Colloquial Yiddish – Complete Course for Beginners*, New York: Routledge Publishing
4. Rosten, L. (2007), *The New Joys of Yiddish*, New York;
5. Wolfthal, D. (2004), *Picturing Yiddish: Gender, Identity, and Memory in the Illustrated Yiddish Books of Renaissance Italy*, Boston: Brill's series in Jewish Studies.





"HENRI COANDA" AIR FORCE ACADEMY  
FACULTY OF AERONAUTICAL MANAGEMENT  
ROMANIA

STUDENTS' INTERNATIONAL CONFERENCE AFASTUD 2015  
*Communicating Across Cultures*  
Brasov, 2<sup>th</sup>-4<sup>th</sup> April 2015



"GENERAL M.R. STEFANIK"  
ARMED FORCES ACADEMY LIPTOVSKY MIKULAS  
SLOVAK REPUBLIC

# COMPARATIVE STUDY BETWEEN 'GEPARD B2L' ANTI-AIRCRAFT DEFENCE SYSTEM AND 'GDF-103 AA- OERLIKON' ANTI-AIRCRAFT CANNON

**Cosmin-Viorel RUSU**

„Henri Coandă” Air Force Academy, Braşov, Romania

**Abstract:** *Air defence systems has known over time a wide development process due to rapid modernization of technology and also appearance of increasingly dangerous and powerful aircraft types. Despite that fact, mankind tried to adapt more and more to the potential flying dangers. Two of the best examples of modern anti-aircraft systems are anti-aircraft cannon GDF-103 AA OERLIKON and anti-aircraft defence system GEPARD B2L. These systems have appeared in military armies since late 1970's knowing a lot of improvements during time. These weapons still represent for many economic global forces, such as Germany, Canada or Swiss, a powerful method of combating air targets. These systems were brought by Romanian army in late 1990's, which represent the apogee of development of of anti-aircraft artillery. The two acquisitions of Romanian army has outstanding performances firstly due to modern types of ammunition which have very diverse destroying effect.*

**Keywords:** *Gepard B2L system, GDF-103 AA Oerlikon system, technology, improvements, comparison.*

## 1. INTRODUCTION

Anti-aircraft defence system GHEPARD B2L and anti-aircraft cannon GDF-103 AA are intended to combat aerial targets at very low, low or partially medium heights, and also they are meant to destroy light armored land targets or even on the water surface. Both systems have the same calibre, using two cannons of 35 millimetres each. These weapons are widely used by a lot of countries which adapted their defence systems to the complexity of modern battlefield. Both of these two weapons are able to combat aerials targets in any weather conditions even if it is night or day. These two “monsters” represent the most effective and modern anti-aircraft

artillery systems which Romanian Army has in its service. During the time they proved their quality in different multinational trainings, being praised by all of our foreign allies which chosen to train with our armed forces.

## 2. DESCRIPTION

GHEPARD B2L anti-aircraft defence system has its origins on Leopard tank 1, having its chassis and then being mounted a large turret on. The turret includes arms, which consists in two 35 millimetres caliber automatic gun Oerlikon KDA, and the two radar antennas one for searching and another for follow-up. Laser rangefinder is on the front of the turret, between the two guns. Each gun has a rate of fire of 550 rounds per

minute. Cannons have a length of a 3.15 meters, with a initial velocity of the projectile of 1,440 meters per second ( using FAPDS projectiles, sub-caliber shot Fragos perforation with removable sabot), and an effective fight of 5500 meters. Automatic guns KDA can use two different types of ammunition, anti-aircraft cannon being usually equipped with 640 anti-aircraft projectiles and 40 projectiles for the ground targets. The transition from one type of ammunition to another is automatic. The turret powered by a 40 KW generator. To create the supply voltage, GHEPARD is equipped with a diesel auxiliary engine of 90 hp Mercedes-Benz OM 314 four-cylinder 3,8 liter.

The vehicle has its own navigation system and two panoramic telescopes. Research radar has a range of 15 kilometres and can operate in motion, data being updated in every second. Recognition of a ally and also enemy is automatic. Tracking radar sends automatically data to fire control system referring to target coordinates and parameters. This system has an analogue computer, which automatically guides the projectiles to target.

The Oerlikon 35 mm twin cannon is a towed anti-aircraft weapon made by Oelikon-Contraves enterprise (renamed as Rheinmetall Air Defence AG following the merger with Rheinmetall in 2009). This twin barrel 35 mm gun has an Fire Control Unit Skyguard that detects and tracks targets up to 20 km and computes fire data. The first prototype of this was completed in 1959 under the designation 1 ZLA/353 MK, which was renamed GDF-1. In 1980, the GDF-002 model was introduced. More than 2000 of guns were produced and sold in approximately 30 countries. In 1980, the Oerlikon 35 mm GDF-002 automatic anti-aircraft gun is used primarily as a anti-aircraft weapon, but can also be applied against ground targets. In may 1985, the GDF-005 was introduced. This is an overall improvement of the GDF 001/2/3 and the

earlier models can be modified to the GDF-005 standard by the use of combat improvement kits supplied by Oerlikon Contraves. The GDF-005 features a new autonomous gun sighting system, an on-board power supply system, an automatic reload and other improvements. Later the GDF-005 was upgraded with AHEAD system, and named GDF-007. AHEAD technology, developed by Oerlikon Contraves, improves the capability of air defence guns such to engage and destroy aerial targets, from large aircraft to small targets such as missiles or PMG's (Precision Guided Munition). With the addition of AHEAD modernisation, existing Skyguard fire are fitted with the fire control subsystems which enable the system to be operated as a stand-alone gun or in a "fire unit network", separated up to three kilometres from each other.



1. A modernized 35 mm Oerlikon twin cannon

These are the most important variants of Oerlikon 35 mm twin cannon:

- **GDF-001:** first version ;
- **GDF-002:** which featured an improved sight and the ability to be directed by an off-gun digital control system;
- **GDF-003:** similar to GDF-002, but included some enhancements like self-lubricated weapons and integrated protective covers.



- **GDF-005:** has several overall improvements that can be retrofitted to existing GDF versions using modification kits. One of the main improvements is the fitting of the Gunking 3-D autonomous computer-controlled optronic sighting system, which eliminates the need for the gunner to estimate target parameters.
- **GDF-007:** upgrade of GDF-005 with AHEAD system

### 3.COMPARISON

GHEPARD B2L and GDF-103 AA systems has the same calibre (35 millimetres) and Oerlikon-Contraves enterprise actually created the cannons for both of these weapons which means that they are using the same type of ammunition. The ammunition is very developed, having a lot of modern types of missiles:

- **HEI:** High Explosive Incendiary;
- **SAPHEI:** Semi-Armor Piercing High Explosive Incendiary;
- **FAPDS:** Frangible Armor Piercing Discarding Sabots;
- **AHEAD:** Anti-missile rounds, that fire "152 heavy tungsten metal sub-projectiles";
- **TP:** target practice;

Basically having the same type of gun and using the same type of ammunition, means that the characteristics of the projectiles are the same. Also the fire rate is the same, those two guns being able to shoot 1100 rounds per minute.

GHEPARD B2L is an armed self-propelled anti-aircraft system, which has been

built on the Leopard 1 chassis. This thing means that being self-propelled gives to that weapon a way better mobility in battlefield than GDF-103 which is a trailed system. Its maximum speed is about 65 kilometres per hour on straight road. Also being armed gives a fully protection to the personnel against low calibre bullets, shrapnel or any other weapon of mass destruction. The personnel of GDF-103 AA are very exposed to those dangers, because this system has poor armor, his only way to stay untouched is to use his camouflage capacity. Speaking about camouflage capacity GHEPARD B2L has a disadvantage comparative to GDF 103-AA because of its dimensions, measuring 3.29 metres in high, 3.27 in width and 7.68 metres in length.



2. GEPARD B2L

Being a very mobile anti-aircraft system, which is a great advantage, GHEPARD B2L has also a disadvantage because it must be fuelled with diesel in order to move. And according to his weight, he consumes a large amount of fuel and that fact represents a lost in budget. Its weight is about 47.3 tones fully equipped. GDF-103 AA is cheaper to use because it is a trailed system and it is much

lighter than GHEPARD, its weight being about 6.586 kilograms fully equipped.

Even if GEPARD B2L is a very large vehicle it doesn't require a large number of personnel too in order to control it. That weapon needs only three soldiers, comparative to Oerlikon cannon, which requires a 9 men crew.

On GDF-103 AA the ammunition containers are on each side of the cradle and rotate with it. Each fully loaded ammunition container holds 56 rounds. The ammunition is reloaded in seven-round clips from the reloading container and passed through the upper mount trunnions to the cannon.



### 3. Romanian 35mm Oerlikon twin cannon firing with TP missiles

GEPARD B2L has on single gun 320 anti-aircraft projectiles, and also 20 projectiles for ground targets. The two 35 mm cannons are working on the base of gas borrow system. Both of them has a strong blocking system, and they are situated outside the turret. Guns can be used from long distances in normal function (electro-hydraulic). Guns can shoot with different types of ammunition which take it from the main ammunition store (anti-aircraft targets) and from the fixed store (ground targets). Ammunition distribution from ammunition storage to each gun, is sustained on each side by a booster. This can be an advantage for GEPARD, because during the fight it doesn't require to many ammunition supply operations. 35 mm

Oerlikon twin cannon has few rounds in its containers, and that is a great disadvantage, because that weapon must have in its crew some soldiers who's duty is to supply the gun with other ammunition containers. On the other hand, even if GEPARD has a lot of ammunition in its containers, that can be turned into a negative fact, because during a fight far away from a military base it can run out of ammunition, and in that point that system will be completely useless.

A typical battery of GDF would consist of two 35 mm anti-aircraft twin guns, each with a power supply unit and fire control unit. The guns are controlled by a single **Skyguard fire control radar**. During a regular mission the 35 mm guns are controlled by a fire control unit, but they also can be operated in local mode by the gunner and the two gun loaders, where the gunner is using a joystick for control and a sight for aiming. A crew of three or in 2 minutes 30 seconds can bring the weapon into the firing position in 1 minute 30 seconds by one. A hand pump is also fitted and when it is used the weapon can be brought into action in 5 minutes.

GEPARD B2L has incorporated in its structure all the systems that are needed to complete its mission. That means that destroying the enemy can be done in more effective time, because the crew of GEPARD has all they need close to them, inside the machine.

The detecting and tracking radar of Oerlikon is better than the radars of GEPARD B2L. Oerlikon system is able to detect targets up to 20 kilometres, and GEPARD can observe the target only up to 15 kilometres.

## 4. CONCLUSIONS

Judging by their performances and equipment, there is no doubt about the value and effectiveness of these two weapons. They are a top method to destroy aerial targets which fly at a low or partially medium



"HENRI COANDA" AIR FORCE ACADEMY  
FACULTY OF AERONAUTICAL MANAGEMENT  
ROMANIA

STUDENTS' INTERNATIONAL CONFERENCE AFASTUD 2015  
*Communicating Across Cultures*  
Brasov, 2<sup>th</sup>-4<sup>th</sup> April 2015



"GENERAL M.R. STEFANIK"  
ARMED FORCES ACADEMY LIPTOVSKY MIKULAS  
SLOVAK REPUBLIC

heights, and also ground targets. This thing is proved by the number of countries who chose to use this technology. Even if they were created long time ago, during the time these systems has been improved a lot according to the massive technology development , and they still represent one of the most important artillery weapons for a lot of industrial forces.

The gun is the same for each of them, being created by Oerlikon Contraves enterprise, which means that Oerlikon and GEPARD belong to the same family. Having the same type of gun and ammo, the power of destruction is the same and also the performances of different types of projectile. GEPARD has a little more advanced ammunition system, because of those 20 rounds used especially against ground targets

or against dangers which flows on the water surface. Also GEPARD has a disadvantage because of its dimensions and weight. But, besides that there is no disadvantage in front of the Oerlikon. GEPARD is faster and has a way better mobility in battlefield, which is the main quality of an anti-aircraft weapon. GEPARD is self-propelled, and that means that all the systems needed to destroy the enemy are inside the machine close to the crew, and can operate in any place of battlefield. Also the personnel is fully protected against mass destruction weapons, and it can complete missions of fighting in any weather conditions.

## **BIBLIOGRAPHY**

\*\*\*. (2003). *Manualul instructiei artileristului antiaerian din fortele terestre, Sistemul 2x35 mm "Oerlikon"*. Sibiu







## Comparative analysis on the implementation of the approach flight with ILS and MLS systems use

Stroescu Cătălin Ionuț\*

\* Faculty of Aeronautical Management, "Henri Coandă" Air Force Academy, Braşov, Romania

**Abstract:** *The hardest part of a flight is often the landing. In many cases the weather conditions may be unfavorable and because of this pilot facilities provided must be independent of weather conditions, allowing it to take a decision at the end of the approach procedure. The ILS (Instrument Landing System), was designed to provide a precise approach, with indications about the center of the runway and the descending slope on the final approach to the direction beacon and slope beacon. Landing systems working in the centimetric wave range, known as short MILS or MLS (Microwave Landing System) are designed to provide onboard for the service of the crew and of the automatic aircraft control system, information on deviations from the path of landing, horizontally and vertically, the minimum distance from the runway threshold, the weather, the state of PDA, the minimum height for secure landing. Different versions of MLS were made in order to gradually replace ILS landing systems.*

**Keywords:** *Landing, azimuth, slope, microwaves, secure flying.*

### 1. INTRODUCTION OF SYSTEMS

#### 1.2 The ILS System

Instrumental Landing System (ILS) has existed for about 40 years but it is currently the most accurate landing system used by civil airlines and military aviation units. Using the system, the pilot obtains real data for an instrumental runway approach.

The Instrumental Landing System is a system which provides to the pilot information about aircraft position (vertically and horizontally), obtaining the precision aircraft guidance when approaching for landing and when landing on a runway. For this, the ILS system is using a combination of radio signals and also high intensity lightening arrangements, designed to give additional safety for the approach flight, indifferently of the weather conditions in which the flight is performing.

The ILS system, with all the radio technical resources from the aircraft and from

the ground, in any weather conditions, is providing the next features to the pilot:

- To maintain a precise approach direction on landing, properly with the vertically plane that is going through the center of the runway.

- Keeping the approaching direction on landing, to descend after a predetermined angle, using a slope, in the way it can reach the optimum point of touching the runway.

- To determine the distance to the threshold

The ILS is solving also some navigation problems, like:

- Entering through the center of the runway and keeping the landing direction until the threshold.

- Helps to maintain the aircraft on the wanted descending slope until the pilot can see the runway

- The determination of the approximate distance to a reference point (ILS point)

- Offers the possibility to correct the accidental errors on the landing direction, without complex calculations



Fig 1.1 Glide Path beacon of the ILS system

Considering the reliability and the integrity of the constitutive devices, as also the precision, the ILS systems are classified in 5 performance categories which determine the operational exploitation of the airdrome:

- ILS system category I is the lowest performance system, which allows the execution of the approaching procedure to a decision making height of 60m and a horizontal visibility of 800m
- ILS system category II has a higher performance, allowing the execution of the approaching procedure to a decision making height of 30m and a horizontal visibility of 400m. The majority of the international airports are equipped with this type of ILS.
- ILS system category III A allows the execution allows the execution of the approaching procedure to a decision making height of 0m and a horizontal visibility of 200m
- ILS system category III B allows the execution of the approaching procedure to a decision making height of 0m and a horizontal visibility of 50m
- ILS system category III C has the highest performance, allowing the execution of the approaching procedure to a decision making height of 0m and a horizontal visibility of 0m

## 1.2 The MLS system

The landing system MLS is the one which facilitates in a remarkable way some attributes, thanks to the advantages that the whole system is disposing. This system is used

because of its small size and because of the thing that it is mobile and can be moved easily, and it's deployment can be made in only a few hours. The American operators prefer this system because of its high reliability.

Many landing systems can suffer from some jamming, but this system is not affected by the ground vehicles or by the taxiing of the aircrafts which are passing through its range. Another advantage that gives this system quality is determined by the fact that it is not suppose the framing into a slope angle established by the RFD for a safe landing, and another very important thing is that this system offers the possibility to land when there is minimum of visibility ,or even if it's equal to 0.

The pilots, as the ground personnel, can obtain information about weather conditions using this system. Information can be about visibility, wind speed, wind direction, barometric pressure, clouds and other information about wind.

In the structure of the system, we can find ground installations, but also aircraft equipment. The determination of the angular position of the aircraft it's made by calculating onboard the time between two pulses. By knowing the time when da information has been transmitted, we can scan the value of the azimuth.

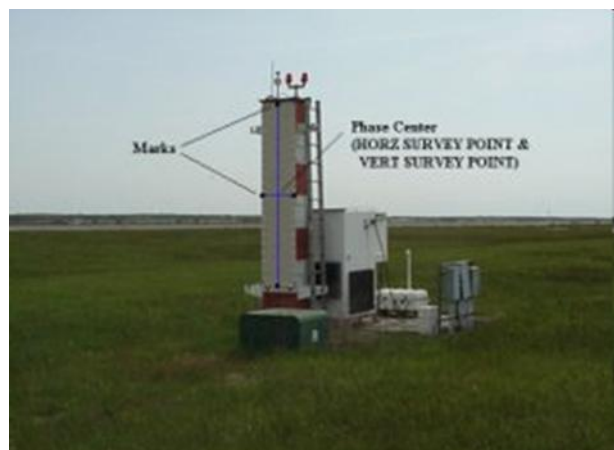

Fig 1.2 Vertically guiding station from the

MLS system

The Landing system MLS was designed to assure:

- the exit of the aircraft to the landing area



- the control of the aircraft in the landing area
- the maneuvering of the aircraft in terms of descending when following the path until reaching the ground and, eventually, taxiing on the ground until full stop for the complex systems.

## 2. CONCEPTS

### 2.1 ILS Concept

An ILS system is made of a set of devices and equipment arranged on the ground and in the aircraft.

On the ground the main components are:

- A direction beacon
- A slope beacon
- 2 or 3 radiolabels
- monitors
- devices for command and for distance signalization
- power supply system

In the aircraft we find the next components:

- a receiver for the signals from the direction beacon
- a receiver for the signals from the slope beacon
- an indicator which has 2 needles in cross
- a receiver for the signals from the radiolabels
- a device for optical and sound signalization when receiving signals from the radiolabels

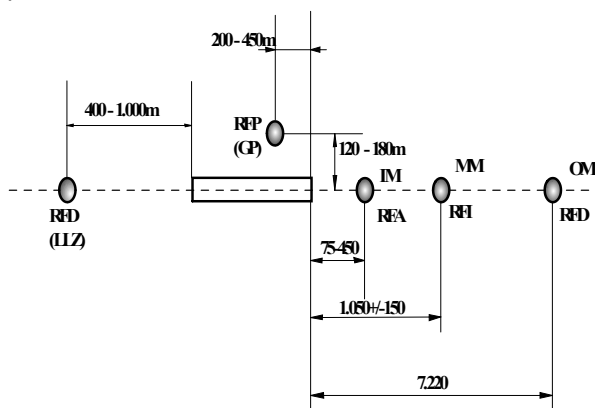

Fig 2.1 The arrangement of the ILS devices on the ground

The radiolabels send an elliptical petal of 1000 ft. over the antenna with the dimensions of 2400 ft. width and 4200 ft. length. The radiolabel receivers from the aircraft must be used on low sensitivity for a good reception of the ILS radiolabel signals.

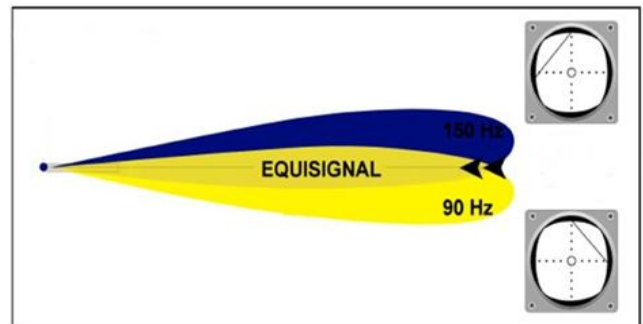

Fig 2.2 The elliptic diagram

Normally, there are two radiolabels associated with the ILS system: OM and MM. The ILS systems category II and III also have an IM. When the aircraft is flying over the radiolabels, the pilots receive the next signals:

- OM: it indicates the position when an aircraft will receive the ILS landing slope at an established height
- MM: it indicates the distance of 3500 ft. to the runway threshold and it signals the thing that the aircraft should be at about 200 ft. over the runway height.
- IM: it indicates the point when the aircraft reached the decision making height.

The ILS system becomes not usable when:

- the direction beacon is out of order: the ILS approach is not authorized anymore
- the slope beacon is out of order: the ILS approach is not precise anymore.

In some cases in the ILS system is installed also a DME station for a bigger precision, this fact making the aircraft more safe in the landing procedure. Using the DME system the pilot can obtain precise information about the distance to the runway.

## 2.2 The MLS Concept

The structure of the MLS system involves both ground equipment and equipment which is located on the aircraft.

The ground equipment is responsible for the limits of the zones in which the information about the position and the distance of the aircraft are received. The ground system is made from azimuthal and telemetric subsystems. The azimuthal subsystem has 4 channels for measuring the angles: 2 azimuthal beacons and 2 beacons for measuring the vertical angle.

There are four types of beacons:

1. Azimuthal Beacon RFA1-used for determining the position of the aircraft compared to the landing direction.
2. Azimuthal Beacon RFA2-used for determining the position of the aircraft compared to the landing direction when flying on the second lap, which means the repeating of the landing.
3. Angular Beacon RFU1-used for determining the vertical angle of the aircraft which is on the landing slope
4. Angular Beacon RFU2-used for determining the vertical angle of the aircraft which is on the recovery zone.

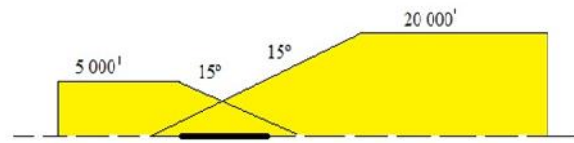
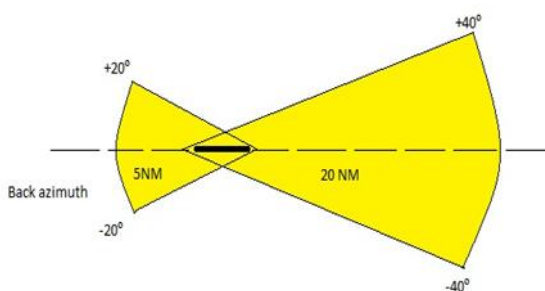

Fig. 2.3 MLS beacon range

The MLS system is working on a 5GHz frequency with two separate channels of 300 KHz. The system is capable to have a range of 60° horizontally, but only 40° can be used and also 20° for a missed landing. The vertical range is between 0,9° to 15°, to a maximum altitude of 6000m, for a distance of 37km from the runway and an altitude of 1500m and 9km for a missed landing.

The determination of the angular position is made by comparing onboard the time between the two pulses, T1 and T2, from the signal obtained after the reflection from the aircraft. The initial moment from the onboard equipment is the moment of receiving the start pulse. The determined value allows the recognizing of the affiliation of the information onboard, so it can be azimuth, for the landing direction or angle for descending or recovery.

## 3. CONCLUSIONS

These 2 systems are used for the same purpose, but they have different specifications. The ILS system has the advantage that, temporally, it has been developed before the MLS system, which is a relatively new system. So, the ILS was implemented widely, using its categories (ILS I, II or III), fact that made possible the accommodation of the personnel with the technical specifications and properties, but also it was possible to equip the aircraft with the necessary equipment for using it.

However, technically, the MLS is considered more profitable because it has smaller size, bigger precision, low power consumption and it can be easily split in parts.



Using this system allows us making economy of fuel and time, but also flexibility in the landing system. The safety and flexibility can ensure that the actual needs of the aviation are satisfied.

Compared to ILS, the MLS can ensure the segmented and curved azimuthal runway approach and also the approach can be made using different angles for the landing slope.

After reviewing what I presented earlier, I consider that even that the ILS system is extremely useful and it was essential for the aircraft control on landing, considering current air traffic it has some disadvantages, like:

- small range for the area in which the information about the direction of the aircraft can be transmitted
- small number of frequency channels
- the dependence of the Direction and slope parameters with the ground specifications and meteorological conditions
- high cost for the construction and using of the system.

These disadvantages can be resolved by the specifications of the MLS system, which was developing to assure:

- information about the azimuthal angle compared to the center of the runway, the angle of the place in the moment of flying and the distance from the runway, and also the same information for a missed landing.

-the necessary safety level for different type of aircrafts, especially for the ones with vertical or short take-off/landing and helicopters, in bad meteorological conditions.

-high precision, safety and independency taking into considerations the meteorological conditions or the area specifications.

-the forming of a linear path of the aircraft with the purpose of growing the air traffic fluency and limiting the sound produced by the airplane

Even that at the first view we can conclude that the MLS system was developed to replace the ILS, however the two systems can work simultaneous, the first one adding some completions to the second one.

## BIBLIOGRAPHY

1. Hladiuc, E.;Popescu, A., *Navigatia Aeriana*, Editura Junimea, Iasi,1977
2. Cîrciu, I.,*Curs Sisteme Radioelectronice de Aviatie si Comunicatii*, Editura Academiei Fortelor Aeriene, Brasov, 2006
3. Comandamentul Aviației Militare, *Manual de navigatie aeriană*, Bucuresti, 1987
4. Boboc, D.; Farkas, A. ;Maria, M., *Curs privind instalarea,exploatarea si utilizarea sistemelor ILS*, Târgu Mureș, 2007
5. Poulouse, M.; Balakrishnan,N , *Microwave Landing System-A favoured alternative to ILS*, Bangalore, 2012





"HENRI COANDA" AIR FORCE ACADEMY  
FACULTY OF AERONAUTICAL MANAGEMENT  
ROMANIA

STUDENTS' INTERNATIONAL CONFERENCE AFASTUD 2015  
*Communicating Across Cultures*  
Brasov, 2<sup>nd</sup>-4<sup>th</sup> April 2015



"GENERAL M.R. STEFANIK"  
ARMED FORCES ACADEMY LIPTOVSKY MIKULAS  
SLOVAK REPUBLIC

## How does terrorism influence the airport security systems?

Szabó Vivien\*, Szegedi Péter\*\*

\* Military Science and Army Officer Training Faculty, National University of Public Service, Szolnok, Hungary, \*\* Military Science and Army Officer Training Faculty, National University of Public Service, Szolnok, Hungary

**Abstract:** *Our study is about the airport's terror sensitivity and it deals with the experiences of terror attacks. It is not occasional that the airports are the main subsystems of the critical infrastructure's system. We would like to present how the airport security system changed and developed in the last decades.*

**Keywords:** *airport security system, explosive, terrorism*

### 1. INTRODUCTION

The terrorism threatens the whole world nowadays. The most important we have to protect our life with human factor, technical infrastructure or with both of them. The terror organizations are partial to threat big buildings, public transportation as bus or train stations. The most dangerous places are the airports because there are a lot of people from all over the world and it is enough only one small piece of explosive to induce a huge accident. The terrorist develop newer and newer methods, and realize attacks. Every miscarriage proves that we need to make our security stricter.

In the history of modern times of terrorism the following parts of airport need significant attention: airplanes on the runway, arrival and departures hall, the air traffic control and radar systems. The weakest points in the airports are the arrival and departure halls. On the internet or on other passenger information sites everybody can reach the flight's data. In this case the offender can find out easy the worthy way to attack.

The check of passengers and their escort friends could not be so efficient than check the

hangars, runways and control systems. In the terminals the waiting people are attacked. We can say that terrorist do not choose their enemies and they shoot down, set off everybody who is there and much more people stay there is much efficient. We need to use the same checking methods all over the world in the air traffic. Only in this case we can protect our life against of attacks. The terror attack on 1<sup>st</sup> of September in 2001 showed us how vulnerable is the air traffic and how serious issue could have a terror action. Similar damage can happen in other big airports in the whole world. From military side it is also important the security of the airfields as logistical and operation viewpoint. (Horváth, Attila, 2009)

In our thesis we would like to introduce the reader how the terrorism influence the development of airport security systems.

### 2. TERRORIST ATTACKS AGAINST OF AVIATION

On 21<sup>th</sup> of December in 1988 a regularly scheduled Pan Am transatlantic flight from London Heathrow Airport to New York JFK Airport was destroyed by a terrorist bomb

above Lockerbie city. Of 350 to 450 grams plastic bomb hidden inside an audio cassette player detonated in the cargo area. Lamin Khalifah Fhimah and Abdel Basset Ali al-Megrahi, chief of security for Libyan Arab Airlines and a suspected Libyan intelligence officer were in connection with the action. (Aviation safety network data base (1988)

On 11<sup>th</sup> of December in 1994 a bomb planted by terrorist Ramzi Yousef exploded, killing one passenger and damaging vital control systems. It was a part of the unsuccessful Bojinka terrorist attacks. (Christopher S. Wren, (1996)

On 11<sup>th</sup> of September 2001 four passenger airliners were hijacked by 19 al-Qaeda terrorists to be flown into buildings in suicide attacks. It was the biggest Al-Qaeda attack against of human life in the history. (Origo, Nagyvilág, (September, 2011)

On 22<sup>nd</sup> of December in 2001 on American Airlines Flight 63 the 2001 shoe bomb plot was a failed bombing attempt. The airplane flew from Paris to Miami International Airport. Richard Reid was subdued by passengers after unsuccessfully attempting to detonate plastic explosives concealed within his shoes. (Richard Reid (January, 2012)

In August of 2006 transatlantic aircraft was a terrorist plot to detonate liquid explosives which traveled from the United Kingdom to the US and Canada. The plot was discovered and foiled by British police before it could be carried out. (Sherwood, Bob, and Stephen Fidler, (August, 2006); (2006 transatlantic aircraft plot, Wikipedia)

On 25<sup>th</sup> of December in 2009 a passenger tried to set off plastic explosives sewn to his underwear, but failed to detonate them properly. The flight was the target of a failed al-Qaeda bombing attempt on Christmas Day. The flight was from Amsterdam Airport to Detroit Airport. (Northwest Airlines Flight 253, Wikipedia)

On 29<sup>th</sup> of October in 2010, two packages contained a bomb consisting of 300 to 400 grams of plastic explosives and a detonating mechanism, were found on separate cargo planes. Saudi Arabia's security chief discovered the bombs. They were bound from Yemen to the United States, and were

discovered at en route stop-overs, one in the UK and one in Dubai. (Information Please<sup>®</sup> Database<sup>©</sup>, 2014); (Cargo planes bomb plot, Wikipedia)

On 2<sup>nd</sup> of March in 2011 two U.S. airmen were killed and two others were wounded at Frankfurt airport when a man opened fire on them at close range with a handgun. (David Mchugh and Juergen Baetz, March, 2011)

On 1<sup>st</sup> of April in 2014 a Lufthansa flight made an emergency return to Munich airport because a refugee from Kosovo armed with a razor blade took a flight attendant hostage. Police apprehended the man. (Deutsche Welle, Aviation, April, 2014)

**2. 1 Summary of attacks.** The demonstrated examples reflect that the terrorist's best "beloved" targets are the airports and airplanes (called: soft targets or sitting ducks). In the airport there are big mass in small place that is why it is much easier for terrorists kill a lot of people from cheap home-made product what is bought from the shops.

The basic condition of the airport's operations is saving and preventing the human life. In the next chapter We would like to introduce what kind of instruments are involved in the airport security system and how built one airport up by security view.

### 3. SECURITY AREAS AT THE AIRPORTS

We classify the airports from security viewpoint to more categories (Fig. 1.).

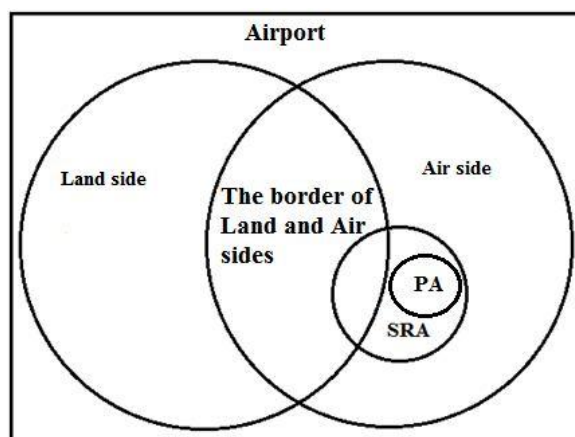

Figure 1. Security zones at the airports





"HENRI COANDA" AIR FORCE ACADEMY  
FACULTY OF AERONAUTICAL MANAGEMENT  
ROMANIA

STUDENTS' INTERNATIONAL CONFERENCE AFASTUD 2015  
*Communicating Across Cultures*

Brasov, 2<sup>nd</sup>-4<sup>th</sup> April 2015



"GENERAL M.R. STEFANIK"  
ARMED FORCES ACADEMY LIPTOVSKY MIKULAS  
SLOVAK REPUBLIC

The land side is protected least of all, after coming the Air side, the security restricted area and afterwards the private area (abbreviation "PA", as Figure 1.

How these areas are protected and the physical and humane factors do not give 100% security against of terror attack, can be seen in Figure 2.

Land side is a public place which consists of the departure and arrival hall. The Air side is closed from publicity –which is guarded area- and only visited with permission which can be a boarding pass or worker's special airport identity card. The Air and Land side border is the passenger security screening for example. There are other gates where is possible to get throw from Land side to Air side but we need to the also the security screening. The Air side can be surrounded by fence against of Land side or the environment around the airport.

The Security Restricted Area is a special place in the airport (for example Hold Baggage Checking System) where for the entire is necessary the permission.

The private area is located in SRA, and we need more permission to go into (for example: Air Traffic Control Tower). (Az Európai Parlament és a Tanács 300/2008/EK rendelete, 2008)

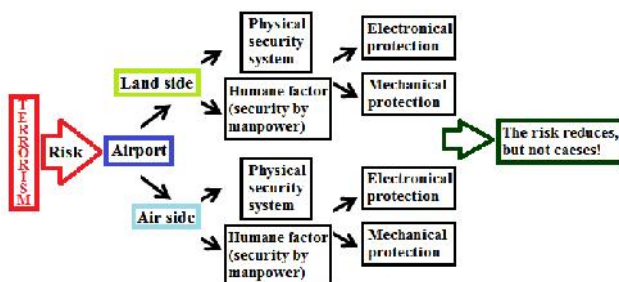

Figure 2.

#### 4. PASSENGER AND BAGGAGE SECURITY SYSTEMS

We would like to present the security procedure ("Airport passenger security is an activity aim at screening the passengers, airlines workers (including flight crew), baggage, items, parcel, board maintenance provider instrument and supply. It is against of guns, explosives, miscarriage, or other dangerous devices and material which are dangerous for civilian air traffic and getting into the closed area of the airport and into the airplanes." (BM Rendelet, 2005)) as we would travel by airplanes and we just step into the airport terminal. At first we go to the check-in desk if we have big drop-off luggage and after we continue our way to the passenger security screening.

We take difference between baggage if we choose the flying to get from point "A" to the point "B". The check-in baggage is separated from the passenger and it is controlled by an automatic system which is located in a private place. It is called Hold Baggage System. These bags are checked by X-ray and explosive detector machines. Airports have different Hold Baggage System which consists of different levels and it is a critical link in aviation security. We would like to demonstrate a system which has 5 different levels.

Level 1<sup>st</sup>: baggage is automatically checked and the system decides in connection with X-ray pictures.

Level 2<sup>nd</sup>: the operator checks the suspicious bag, if he/she thinks it is clean to let the bag into the transit if not to send the bag the next level.

Level 3<sup>rd</sup>: It is a more extensive examining than the Level 1<sup>st</sup>. These machines have a different proceeding.

Level 4<sup>th</sup>: the operator checks again the bag after the Level 3<sup>rd</sup>, the luggage can go afterward to the next level or to the transit.

Level 5<sup>th</sup>: in this case it is a must to open all bags which are arrived to the level, it does not matter if the owner takes part in the examining or not. (Hold Baggage Screening Systems, Geo Robson & Co (Conveyors) Ltd)

#### **4.1 Check-in luggage scanner machines.**

For example the HI-SCAN 10065 HDX Baggage scanner: This machine discovers and identifies explosives automatically. These machines can be used in all 3 levels of the Hold Baggage System or stand-alone by the passenger security screening. Approximately 400 bags per hour can be checked by this device. The luggage is only exposed to a localized, low X-ray dosage.

The passengers usually meet with these machines by the security screening:

- baggage scanner
- liquid explosives detector
- walkthrough metal detector gate
- hand-held metal detector
- drug sensor/analyzer.

(Smiths Heimann, datasheet, smiths-heimann.com)

**4. 2 Passenger Security Screening instruments.** Smith HI-SCAN 6040 aTix machine is automatic detection of explosives in hand luggage. It shows real time evaluation and dual view what means two high-resolution pictures on the monitor. This device includes lower false alarms and TIP –Threat Image System- functionalities which means that the computer creates false pictures and the operator need to realize it and in this case he needs to push the bottom on the keyboard and if the false object disappears on the pictures the baggage is clear and there is no need to further examining. This program creates unusual forbidden instrument and it keeps fit the human worker's attention.(Smiths detection, smiths-heimann.com)

#### **4.3 CEIA 02PN20 Walk-Through Gate.**

It is capable to detect all the metal weapons on the body or inside. It is possible to adjust the intensity level. But it is not possible to detect the liquids only the metal objects. There is chip card what changes the secure parameters.

It consist of 60 localization zones, anti-vandalism, anti-tampering protection, no periodic re-calibration. (Costruzioni Elettroniche Industriali Automatismi, 02PN20/EZHD Elliptic, Multi-Zone and Heavy Duty Enhanced Metal Detector)

**4.4 EMA liquid explosive detection system.** EMA checks automatically the sealed and unsealed liquids, aerosols and gels. It does not matter if the bottle is clear, colored, plastic or glass, metal and metalized containers. It is an optional devices which makes the screening much more safely. It does not consist of ionizing source or part in movements.

Simultaneous Explosives and Narcotics Trace Detector detects over 40 substances and identifies in 8 seconds. This device is able to detect and identify explosives and narcotics during a single analysis. For example RDX, PETN, NG, TNT, HMX, TATP explosives are detected and Cocaine, Heroin, Amphetamine, Methamphetamine, MDA, THC narcotics are also detected. Usually baby carriage and madness are checked by this instrument because it is not possible to lay into the baggage scanner. (Costruzioni Elettroniche Industriali Automatismi, EMa series Type B with integrated Type A\* LAGS Analyser)

## **5. CONCLUSION**

In our thesis we wanted to introduce the reader what kind of terror attack happened in the past and because of them what kind of instruments are taken in the airport security checking system. After the memorabilia we can say that nowadays the innovation of airport's equipment is pretty important and these will be never work with 100% efficiency. Unfortunately we can see that new successful or less successful terror attacks come true and it points out the imperfection of security system. For example the last order from American Traffic Authority in 2014 was that laptops must be checked randomly and people cannot use their phones until throwing pass the passenger security process. The researches show that the psychological examining would be a great control system but this method takes a lot of time and money. In the future we need to prepare our specialists to notice the suspicious effects of terror and as soon as



"HENRI COANDA" AIR FORCE ACADEMY  
FACULTY OF AERONAUTICAL MANAGEMENT  
OMANIA

STUDENTS' INTERNATIONAL CONFERENCE AFASTUD 2015  
*Communicating Across Cultures*

Brasov, 2<sup>nd</sup>-4<sup>th</sup> April 2015



"GENERAL M.R. STEFANIK"  
ARMED FORCES ACADEMY LIPTOVSKY MIKULAS  
SLOVAK REPUBLIC

possible they need to take a right and necessary measure. If a terror attack started our professionals need to behave correct for the situation and we need to prepare also the passengers and population – using the possibilities of education system and media-how to behave if we are in the middle of a terror attack.

### BIBLIOGRAPHY

1. Aviation safety network data base (1988): Criminal Occurrence description *Source*. [online]. Available: <http://aviation-safety.net/database/record.php?id=19881221-0>
2. Christopher S. Wren (1996): Plane Bombing Is Described in Terror Trial, The New York Times, *Source*. [online]. Available: <http://www.nytimes.com/1996/06/04/nyregion/plane-bombing-is-described-in-terror-trial.html>
3. Origo, Nagyvilág (September, 2011): "Az elnököt is értesíteni kellene" - 2001. szeptember 11. a pilótafülkéből, Origo, *Source*. [online]. Available: <http://www.origo.hu/nagyvilag/20110909-usa-szeptember-11-a-terrortamadas-tortenete.html>
4. Richard Reid (January, 2012): CASE STUDY, *Source*. [online]. Available: <http://theriskyshift.com/2012/01/richard-reid-shoe-bomber-html/>
5. Sherwood, Bob, and Stephen Fidler, (August, 2006): MI5 Tracked Group for a Year, Financial Times, *Source*. [online]. Available: <http://ft.com/cms/s/cbed2e12-28b5-11db-a2c1-0000779e2340.html>
6. 2006 transatlantic aircraft plot, Wikipedia, the free encyclopedia *Source*. [online]. Available: [http://en.wikipedia.org/wiki/2006\\_transatlantic\\_aircraft\\_plot](http://en.wikipedia.org/wiki/2006_transatlantic_aircraft_plot)
7. Northwest Airlines Flight 253, Wikipedia, the free encyclopedia *Source*. [online]. Available: [http://en.wikipedia.org/wiki/Northwest\\_Airlines\\_Flight\\_253](http://en.wikipedia.org/wiki/Northwest_Airlines_Flight_253)
8. Information Please® Database,© (2014) Terrorist Attacks in the U. S. or Against Americans, Infoplease *Source*. [online]. Available: <http://www.infoplease.com/ipa/A0001454.html>
9. Cargo planes bomb plot, Wikipedia, the free encyclopedia *Source*. [online]. Available: [http://en.wikipedia.org/wiki/Cargo\\_planes\\_bomb\\_plot](http://en.wikipedia.org/wiki/Cargo_planes_bomb_plot)
10. David Mchugh and Juergen Baetz (March, 2011): 2 U.S. airmen killed, 2 wounded in German shooting by Kosovo man, cleveland.com, *Source*. [online]. Available: [http://www.cleveland.com/world/index.ssf/2011/03/2\\_us\\_airmen\\_killed\\_2\\_wounded\\_i.html](http://www.cleveland.com/world/index.ssf/2011/03/2_us_airmen_killed_2_wounded_i.html)
11. Deutsche Welle, Aviation (April, 2014): Man holds flight attendant hostage on Lufthansa plane, *Source*. [online]. Available: <http://www.dw.de/man-holds-flight-attendant-hostage-on-lufthansa-plane/a-17535635>
12. Andrew Roche (April, 2014): German airliner hostage-taking ends after brief standoff, The Star Online, *Source*. [online]. Available: <http://www.thestar.com.my/News/World/2014/04/02/German-airliner-hostagetaking-ends-after-brief-standoff/>
13. BM Rendelet (2005): 1/2005. (I. 12.) BM rendelet az utasbiztonsági ellenőrzést végző személyek e feladatra történő felkészítésének és vizsgáztatásának

- rendjéről, Magyar Közlöny, *Source*. [online]. Available: <http://www.kozlonyok.hu/nkonline/MKPDF/2005/MK4.pdf>
14. Hold Baggage Screening Systems, Geo Robson & Co (Conveyors) Ltd, *Source*. [online]. Available: <http://www.copybook.com/airport/geo-robson-co-conveyors-ltd/articles/hold-baggage-screening-systems>
  15. Smiths Heimann, datasheet: HI-SCAN 10065 HDX Discovers and identifies hidden explosives automatically, smiths-heimann.com *Source*. [online]. Available: <http://www.donggok.co.kr/data/HS10065HDX.pdf>
  16. Smiths detection: HI-SCAN 6040aTiX Heimann x-ray inspection system, smiths-heimann.com *Source*. [online]. Available: [http://www.smithsdetection.com/index.php/products-solutions/explosives-detection-liquids/55-explosives-detection-liquids/hi-scan-6040atix.html?lang=en#.VQ7TJ\\_mG\\_3F](http://www.smithsdetection.com/index.php/products-solutions/explosives-detection-liquids/55-explosives-detection-liquids/hi-scan-6040atix.html?lang=en#.VQ7TJ_mG_3F)
  17. Costruzioni Elettroniche Industriali Automatismi: 02PN20/EZHD Elliptic, Multi-Zone and Heavy Duty Enhanced Metal Detector, ceia.net, *Source*. [online]. Available: <http://www.ceia.net/security/pdf%5C02PN20EZHDbrochureUS.pdf>
  18. Costruzioni Elettroniche Industriali Automatismi: EMa series Type B with integrated Type A\* LAGS Analyser, ceia.net, *Source*. [online]. Available: <http://www.ceia.net/security/pdf%5CEMAseriesbrochureGB.pdf>
  19. Horváth Attila, (2009): A repülőterek és a légiirányítás, mint kritikus infrastruktúrák, Hadmérnök IV. évfolyam 4. szám, *Source*. [online]. Available: [http://hadmernok.hu/2009\\_4\\_horvatha.pdf](http://hadmernok.hu/2009_4_horvatha.pdf)
  20. Az Európai Parlament és a Tanács 300/2008/EK rendelete (March, 2008): A polgári légi közlekedés védelmének közös szabályairól és a 2320/2002/EK rendelet hatályon kívül helyezéséről, *Source*. [online]. Available: <http://eur-lex.europa.eu/legal-content/HU/TXT/PDF/?uri=CELEX:32008R0300&from=HU>



ROMANIA

“Henri Coandă” Air Force Academy

160 Mihai Viteazul st. Brasov 500183

Tel +40 268 423421 [www.ahafc.ro/afastud/arhiva.html](http://www.ahafc.ro/afastud/arhiva.html)

E-mail: [afa\\_stud@afahc.ro](mailto:afa_stud@afahc.ro)