

MODERN TECHNOLOGIES FOR THE REALIZATION OF THE PUMA HELICOPTER BLADE

Ion DINESCU

“Henri Coandă” Air Force Academy, Brasov, Romania

DOI: 10.19062/2247-3173.2016.18.1.3

Abstract: *The main pales represent the helicopters` vital organ. Concerning the flight's security, the pales are the vital organ because a pale's breaking has as a consequence the total destruction of the whole device (plane) because of the lack of poise.*

This paper presents some of the characteristics that concern their building (construction) and materials used in the aeronautic constructions.

Keywords: *technologies, materials, helicopter, blade, construction.*

1. INTRODUCTION

The blades for helicopters have been made out of a composite of wood and metal. The demands concerning the mechanical resistance, the dimensional precision, the humidity and corrosion resistance have changed the structure and technology of execution [1; 3; 4].

The reduction of the unstationary vibrations that drive on each blade is made with the incorporation of some piezo-electrical materials within the structure of the blade.

The recent research for the control of the anisotropic blade, are using the drive on the fibers of the composite structure, the model being experimented on the blade of the main rotor of the Sikorsky H-34 helicopter.

2. ASPECTS OF THE REALIZATION OF THE BLADE

During the flight, the helicopter blades are subdued to very big aerodynamic speed differences while a complete rotation of the engine that can lead to the helicopter's lack of poise [5; 6].

In practical cases this phenomenon is combated by the continuous change of the blade's incidence within its swivel around its longitudinal axle (the changing of the cyclical steep).

On the other hand, the blade is simultaneously subdued to a lifting effort and to the action of the centrifugal force that, once geometrically summed up, could determine an azimuth direction of the blade, case in which at the embedding, towards the log, the flexion of the body of the blade would be cipher.

This direction being valid at every rotation that takes place during a flight, led to the idea of ensuring the blade a second joint called “joint with rotative motion” around an ZZ' axle. Adding a third joint around the YY' axle, in order to absorb the inequality of the resistance when moving ahead, led to a log “totally articulated” universally used, but pretty complicated mechanically speaking [6].

The way in which every joint works ca be observed in figure number 1.

The usage of plastics in what concerns the accomplishment of blades allowed, without reaching the breaking boundary, eliminating two joints, a rotor head being obtained “completely rigid”, but still having the incidence variation. This way, the joint with rotative motion and of the alternative motion have been replaced with the liveness of the blade [2; 4].

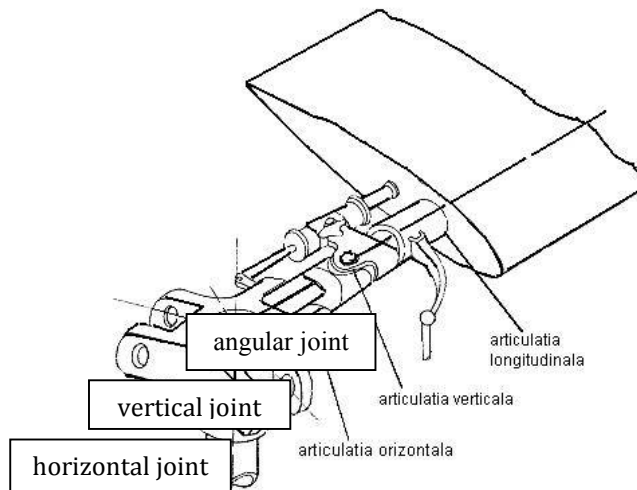

FIG.1. Joint for moving the Puma helicopter blade

The solution embraced determines the growth of the flexion efforts within the embedding, efforts easily taken over by the plastic coverage, because of their great resistance. The efforts are constantly varying, but can be absorbed, because the coverages can almost unlimitedly resist to the alternating tensions.

The ratio between the value of the resistance and the density is a lot higher than in the case of the materials for aeronautic constructions (duralumin, steel), allowing the alleviation of the blades and at the same time the diminishing of the forces. Plus, the reduced density allows the utilization of some more dense materials, less subdued to the local deformation, facilitating the avoidance of the panels’ “swelling”. The vulnerability is also reduced at the impact of the projectiles when talking about military helicopters, the corrosion disappears and the vibrations during the flight are reduced. The fabrication process is relatively easy and quick and the selling price of the blade is also reduced, despite the high prices of these materials [7].

The main blades represent the vital organ of the helicopter, fulfilling the following distinct functions:

- they create the pulling force, necessary for the maintaining in the air;
- they create the pulling force needed for the heading;
- it serves as a commanding organ for the maintaining of the balance during the flight and for the changing of the flight direction.

3. COMPOSITE MATERIALS FOR THE REALIZATION OF THE BLADE

The blade made out of composite materials (figure number 2) has the same realization:

- *the longeron (1)* – made out of glass fibre (network) impregnated with epoxidic resin that incorporates the attaching jacks of the helicopter’s blade;

- *the coverage (2)* – made out of two layers of texture made of carbon fibers impregnated with epoxidic resin and a layer of glass fiber on the outside;
- *the filling (3)* – made for the aerodynamic profile of the blade, built of a plastic honeycomb structure and rigid foam;
- *the trailing edge of the wing (4)* – made out of a gathering of glass and carbon fibers;
- *the end of the blade (5)* – where are being fixed the static and dynamic balancing masses;
- the leading wing edge (6)* – made out of steel armours.

The low density of the composite materials allows when having an equal weight a supra-dimensioning of the areas solicited by tiredness, so then the making of a new blade longer and wider, with higher performances. [1; 3; 4; 7].

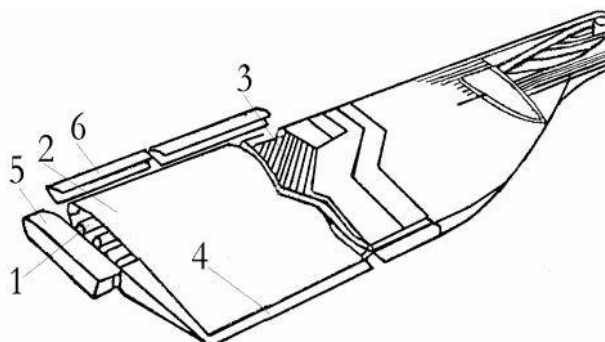

FIG.2. Constituent materials of blade
Puma helicopter

4. MODERN TECHNOLOGIES FOR THE REALIZATION OF THE BLADE

The component parts of the composite blade, as well as the blade itself are being made in special molding devices [2; 4]. The assembling is being made in iron chills warmed up and maintained at 40°C while assembling the components, and then the polymerization of the resin to be done at 120°C, 0.8÷0.9 bars, for 2 hours.

The fabrication begins by the positioning of the layer used for the coverage of protection (glass fiber texture), followed by carbon fiber textures and by the assembling of the other components. The steps must be executed with the maximum of accuracy. The smallest impure material depositions are compromising for the quality of the solder.

The longeron is made out of a bunch of glass fibers – Rowing type – impregnated with epoxidic resin, rapped on a special device. The rapping of every bunch is being made with the help of a special technology that ensures the profile. The checking of the profile is made on a checking device.

The honeycomb structure is being made at the blade's profile on a milling machine.

After the demoulding of the blade the adjusting and finishing operations are made.

Then the solder of the attacking board is next, in a special device with heating that re-feeds an interstice well determined and then controlled.

Composite materials are a new technology that will find increased use in new helicopter structure. Titanium alloy technology also enables lighter wight helicopter, high temperature flight environment.

For a higher speed precision of helicopters, medium density plastic composites should be used, such as fiberglass reinforced phenolic resins containing hylon, silica, graphite or carbon.

These have good resistance to erosion, allow high surface temperatures and exhibit good insulation performance.

Medium density plastic composite materials char at high temperature but generally maintain their thickness and aerodynamical shape. They are usually fabricated by wrapping fiberglass tape over a metal form mandrel, so that the grain of the finished unit is oriented for minimum erosion. After winding, the tape is cured, machined as necessary and assembled with other components using adhesives and sealants.

5. CONCLUSIONS & ACKNOWLEDGMENT

The composite materials, thanks to their extraordinary qualities, which they have imposed in high fields, at which the classical materials do not correspond, represent an efficient way of reducing the consumption in their fabrication as well as in exploitation.

The assessment of helicopter materials technologies addresses five new enabling technologies. These are composite structure materials and reduced parts count structure.

Graphite epoxy and aluminium or aluminium alloys are attractive choices for lighter weight structure. Graphite epoxy and aluminium alloys have high strength to weight ratio, are easily fabricated, have a good corrosion resistance, and are low in cost.

The strength to weight capability of advanced composites is very high. In addition to small diameter fibers, advanced composite structures have long, continuous fibers and a fiber/matrix ratio that is greater than 50% fibers by volume. Fibers can be: carbon (graphite), kevlar, boron, ceramic, silicon carbide quartz, glass, polyethylene and others.

Also the low density of composites further reduces the weight compared to metals.

Graphite fiber composite materials have extremely high modulus of elasticity resulting in low strain and deflection compared to metals.

However, a note of caution, unlike metals that generally yield gracefully before ultimate failure, composite fibers generally fail suddenly without yield.

Aeronautical and spatial constructions work in very difficult conditions compared to those at which are subdued the structures belonging to the building of the machines. As a consequence, the utilization of the composite materials in aeronautics still remains a field in which a lot of research can be done.

REFERENCES

- [1]. Dinescu, I., Eftimie, L., Cătana, D. *Tehnologia materialelor, Tehnologii de bază*, Editura Lux Libris, Braşov (1997).
- [2]. Dinescu, I., *Tehnologia materialelor, Materiale tehnologice*, Editura Academiei Aviației și Apărării Antiaeriene "HENRI COANDĂ", Braşov (2000).
- [3]. Dinescu, I., s.a. *Studiu privind utilizarea materialelor compozite în construcțiile aerospațiale*, Buletinul științific al Sesiunii naționale de comunicări științifice 1-2 noiembrie 2002, Academia Forțelor Aeriene "HENRI COANDĂ", Braşov, pag. 41-50 (2002).
- [4]. Dinescu, I., Smeada, M., Stoicanescu, M. *Materiale moderne utilizate în tehnica militară*, Editura Academiei Fortelor Aeriene "HENRI COANDĂ", Braşov (2012).
- [5]. Ispas, Șt. *Materiale compozite*, Editura Tehnică, București (1987).
- [6]. Marinescu, A., Anghel, V. *Aerodinamica și dinamica elicopterului*, Editura Academiei Române, București (1992).
- [7]. Smeada, M., Dinescu, I., Stoicanescu, M. *Materiale metalice și nemetalice utilizate în tehnica militară*, Editura Academiei Fortelor Aeriene "HENRI COANDĂ", Braşov (2012).